

HeatWise™

Electric Tank Water Heater

INSTALLATION & OWNER'S MANUAL

MODELS:

MTWH045*E
MTWH045*EL
MTWH045*ET



Read this manual carefully before installation and keep it where the operator can easily find it for future reference.

Due to updates and constantly improving performance, the information and instructions within this manual are subject to change without notice.

Version Date: February 24, 2026
Please visit www.mrcool.com/documentation
to ensure you have the latest version of this manual.



CONTENTS

1 SAFETY	2
2 INSTALLATION	5
2.1 Location Selection	5
2.2 Shipment Inspection	5
2.3 Thermal Expansion	5
2.4 Water Supply Connections	6
2.5 Typical Installation	6
2.6 Relief Valve	7
2.7 Filling the Water Heater	7
2.8 Condensation	7
2.9 Energy Cover	7
2.10 Electrical Connections	8
2.11 Energy Efficiency	9
2.12 Hot & Cold Pipe Insulation Installation	9
2.13 Relief Valve Insulation Installation	10
3 POST-INSTALLATION	10
3.1 Installation Checklist	10
3.2 Operating the Water Heater	10
3.3 Water Temperature Settings	11
3.4 Draining the Water Heater	12
3.5 Routine Preventative Maintenance	12
3.6 Extended Shut Down	12
3.7 Anode Rod	12
3.8 Grounding	13
3.9 Troubleshooting	13
3.10 Replacement Parts	14
3.11 Service Needs	15
3.12 Wiring Diagram	15

Safety Precautions

Read Before Using

Incorrect usage may cause serious damage or injury.

The symbols below are used throughout this manual to indicate instructions that should be followed closely or actions that should be avoided to prevent death, injury, and/or property damage.



Indicates the possibility of personal injury or loss of life.



Indicates the possibility of property damage or serious consequences.

SAFETY PRECAUTIONS

- The purpose of this manual is two fold: one, to provide the installer with the basic directions and recommendations for the proper installation and adjustment of the water heater; and two, for the owner-operator, to explain the features, operation, safety precautions, maintenance, and troubleshooting of the water heater. This manual also includes a parts list.
- It is imperative that all persons who are expected to install, operate, or adjust this water heater read these instructions carefully so they may understand how to perform these operations. If you do not understand these instructions or any terms within it, seek professional advice.
- Do not destroy this manual. Please read carefully and keep in a safe space for the future.
- Any questions regarding the operation, maintenance, service, or warranty of this water heater should be directed to the seller from whom it was purchased.
- Inside this manual, you will find many helpful hints on how to use and maintain your water heater properly. Just a little preventative care on your part can save you a great deal of time and money over the life of your water heater.
- You'll find many answers to common problems in the Troubleshooting section. You may not need to call for service at all.
- For your safety, the information in this manual must be followed to minimize the risk of fire, explosion, electric shock, or to prevent property damage, personal injury, or loss of life.
- Be sure to read and understand this entire manual before attempting to install or operate this water heater. Pay particular attention to the safety instructions. Failure to follow these warnings could result in serious bodily injury or death. Should you have problems understanding the instructions in this manual, or have any questions, stop and get help from a qualified service technician, or the local electric utility service.
- Use this appliance only for its intended purpose as described in this manual.
- Be sure your appliance is properly installed in accordance with local codes and these instructions.
- **DO NOT** attempt to repair or replace any part of your water heater unless it is specifically recommended.
- All other servicing should be referred to a qualified technician.
- **DO NOT** turn on the electrical supply or operate the unit unless it is completely full of water.

CALIFORNIA INSTALLATIONS:

- Proposition 65: This product contains chemicals known to the State of California to cause cancer, birth defects, or other reproductive harm.
- California law requires that residential water heaters must be braced, anchored, or strapped to resist falling or horizontal displacement due to earthquake motions. For residential water heaters up to 52 gallon capacity, a brochure with generic earthquake bracing instructions can be obtained from: Office of the State Architect, 400 P Street, Sacramento, CA 95814. You may also call 916-324-5315 or ask a water heater dealer.
- Applicable local codes shall govern installation. For residential water heaters with a capacity greater than 52 gallons, consult the local building jurisdiction for acceptable bracing procedures.



WARNINGS

When using electrical appliances, basic safety precautions to reduce the risk of fire, electric shock, or injury to persons should be followed, including:

- Read all instructions before using this water heater.
- This water heater must be grounded. Connect only to a properly grounded outlet. See the "Grounding Instructions" section in this manual.
- Install or locate this water heater only in accordance with the provided installation instructions.
- Use this water heater only for its intended use as described in this manual.
- Do not use an extension cord set with this water heater. If no receptacle is available adjacent to the water heater, contact a qualified electrician to have one properly installed.
- As with any appliance, close supervision is necessary when used by children.
- Do not operate if the unit has a damaged cord/plug, is not working properly, or has been damaged or dropped.
- This water heater should be serviced only by qualified service personnel. Contact your nearest authorized service facility for examination, repair, or adjustment.
- Do not use volatile oil, alcohol, thinner, etc. to clean the machine, otherwise it may damage the product.
- The installation torque for the inlet and outlet water pipes must not exceed 36.8 lb.ft., otherwise it will permanently damage the structure of the water heater.
- It is forbidden to modify the purpose and function of the product without permission.
- Before cleaning the machine or performing maintenance, disconnect the main power supply.
- If the machine is not used for a long time, please disconnect the main power supply.
- When not in use for a long time, or when the power is off in cold weather, the water must be drained.
- Do not place water containers on live products. Water seeps into the interior of the water heater and weakens the insulation of the electrical appliances, causing electric shock, fire, etc.
- The power supply must be within the specified voltage range of the product.
- Prevent children from entering the interior of the product.
- The safety precautions are clearly stated as hazard prevention matters.
- Do not install the unit around flammable and explosive products, in an environment with strong electromagnetic interference, in an environment with an open flame, or a strong corrosive environment. Also avoid places with safety hazards.
- If there are no independent power supplies, sockets, and other safety switches, do not install the unit.
- The main power supply of the equipment should be located in a place that is not easily accessible to children and should be avoided from being blocked by flammable objects.
- When the installation involves drainage pipes, it must be ensured that the drainage can be done smoothly.
- Take precautions regarding the necessary strength and structure of the installation location (wall, ceiling, etc.), the fixing method of the fuselage, the method of use, and related precautions.
- The auxiliary materials used for installation must comply with local regulations.
- It is recommended to connect the rated specifications of the wiring, the rated specifications of the plug or switch. If the diameter of the user's power cord is too small, it could lead to a risk of fire. If the diameter of the user's power cord is lower than the actual product's required diameter or the diameter does not meet the total power load, it is prohibited to install the product.
- Before installation, it is necessary to check whether the user's home power supply has a ground wire. If it is found that the user's home power supply has no ground wire, or the power ground wire is detected to be energized, and there are no effective on-site rectification measures, it is prohibited to install the product.
- Before drilling holes in walls and floors, if the holes conceal wires or conduits and the locations of wires, water pipes, gas pipes, etc. cannot be clearly identified, you must confirm with the user. You can also use an induction test pen to detect whether there is a power line passing through the drilling location to avoid personal injury accidents caused by the drill bit damaging the power line.
- During installation and maintenance operations, disconnect the main power supply.
- To prevent safety issues such as electrical overload and leakage, it is recommended to install a leakage protection switch when connecting the power cord to the electrical appliance. This will help to promptly cut off the power supply in case of any issues with the unit, protecting you and your family.
- When installing, repairing, or replacing TP valves, inlet and outlet pipes, avoid collision between tools and threads at the connections as this can damage the threads or cause the sealed connection to fail and lead to water leakage.

WARNINGS, CONTD.

- To ensure the safety performance of your home water pipes, we recommend that you choose high-quality pipes (PPR, CPVC, and PEX) that are resistant to high temperature, pressure, and corrosion when installing them.
- To ensure the long-term efficient operation of the water heater, it is recommended having the inner tank cleaned once a year by a qualified installer or plumber to remove the sediment on the electrical components inside the tank.

WATER TEMPERATURE WARNINGS

- Safety and energy conservation are factors to be considered when selecting the water temperature setting of the water heater's thermostat.
- Water temperatures above 125°F (52°C) can cause severe burns or death from scalding.
- Be sure to read and follow the warnings outlined on the label pictured below. This label is also located on the water heater near the thermostat access panel.
- Households with small children, disabled individuals, or elderly persons may require a 120°F (49°C) or lower thermostat setting to prevent contact with hot water.
- The temperature of the water in the heater is regulated by the adjustable service mounted thermostat(s) located behind the jacket access panel(s). Dual element heaters have two thermostats. To comply with safety regulations, the thermostats were set at 120°F (49°C) before the unit was shipped from the factory.
- Mixing valves are recommended for reducing point of use water temperature by mixing hot and cold water in branch water lines. It is recommended that a mixing valve complying with the Standard for Temperature Actuated Mixing Valves for Hot Water Distribution Systems, ASSE 1017 be installed.

DANGER

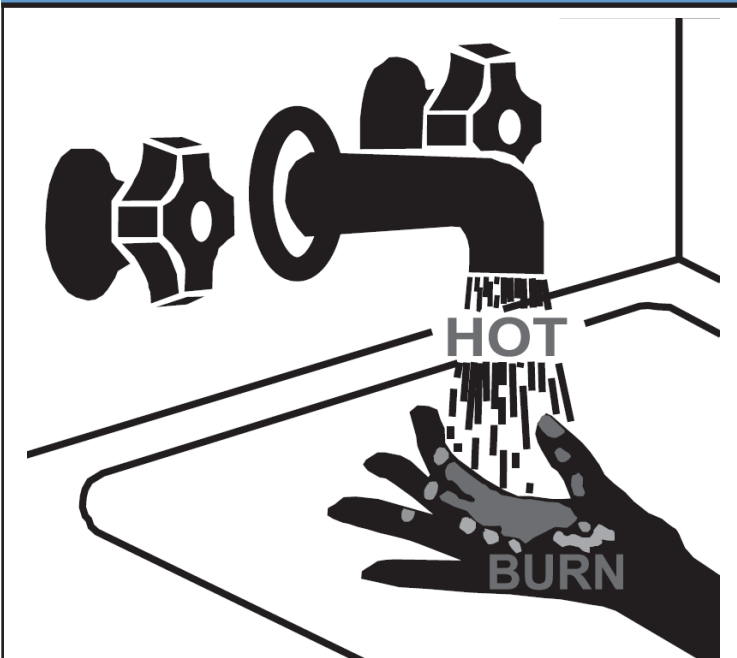

- Water temperature over 125°F (52°C) can cause severe burns instantly or death from scalds.
- Children, disabled individuals, and the elderly are at highest risk of being scalded.
- See the instruction manual before setting the water heater's temperature.
- Feel water before bathing or showering.
- Temperature limiting valves are available.

Temperature	Time to Produce a Serious Burn
120°F / 49°C	More than 5 minutes
125°F / 52°C	1.5-2 minutes
130°F / 54°C	About 30 seconds
135°F / 57°C	About 10 seconds
140°F / 60°C	Less than 5 seconds
145°F / 63°C	Less than 3 seconds
150°F / 66°C	About 1.5 seconds
155°F / 68°C	About 1 second

The chart above may be used as a guide in determining the proper water temperature for your home.

FOR YOUR RECORDS:

Write the model and serial numbers here. You can find them on a label on the unit. Staple the sales slip or canceled check here. Proof of the original purchase date is needed to obtain service under the warranty.

MODEL #: _____

SERIAL #: _____

2 INSTALLATION

2.1 Location Selection

Regulations

This water heater must be installed in accordance with these instructions, local codes, utility codes, utility company requirements or, in the absence of local codes, the latest edition of the National Electrical Code.

Location

Install the water heater in a clean, dry area as near as practically possible to the area with the greatest demand for heated water. Long, uninsulated hot water lines can waste energy and water.

Place the water heater in such a manner that the thermostat and element access panels can be removed to permit inspection and servicing such as removal of elements or checking controls.

The water heater and water lines should be protected from freezing temperatures. Do not install the water heater in outdoor, unprotected areas.

Make certain the floor underneath the water heater is strong enough to sufficiently support the weight of the water heater once it is filled with water.

It is prohibited to install water heaters in bathrooms, outdoors, or in other humid or open environments to prevent electrical malfunctions.

! CAUTION

The water heater should not be located in an area where leakage of the tank or connections will result in damage to the area adjacent to it or to lower floors of the structure. Where such areas cannot be avoided, it is recommended that a suitable catch pan, adequately drained, be installed under the water heater.

NOTE

The auxiliary drain pan must conform to local codes.

Drain pan kits are available from any water heater distributor.

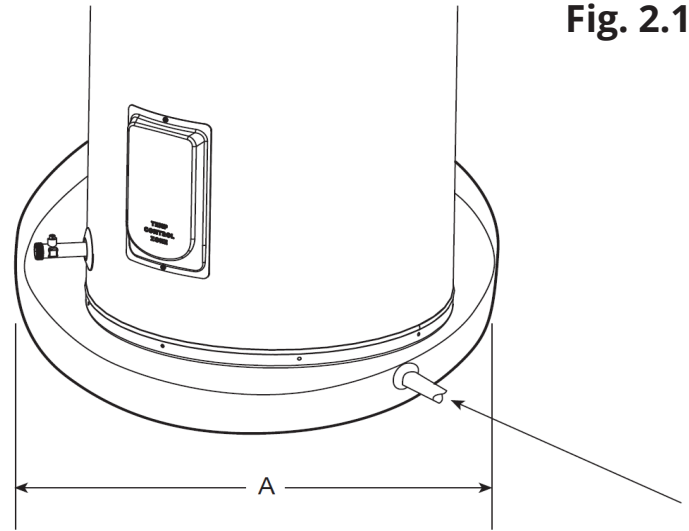

Fig. 2.1

2.2 Shipment Inspection

Inspect the water heater for possible damage. Check the markings on the rating plate of the water heater to be certain the power supply corresponds to the water heater requirements.

2.3 Thermal Expansion

When a water heater is installed in a closed water-supply system, such as one having a backflow preventer in the cold-water supply, means should be provided to control thermal expansion. Contact the water supplier or local plumbing inspector for information regarding the control of the situation.

Determine if a check valve exists in the inlet water line. Check with your local water utility. It may have been installed in the cold water line as a separate back flow preventer, or it may be part of a pressure reducing valve, water meter, or water softener. A check valve located in the cold water inlet line can cause what is referred to as a "closed water system". A cold water inlet line with no check valve or back flow prevention device is referred to as an "open" water system.

As water is heated, it expands in volume and creates an increase in the pressure within the water system. This action is referred to as "thermal expansion". In an "open" water system, expanding water which exceeds the capacity of the water heater flows back into the city main where pressure is easily dissipated.

A "closed water system", however, prevents the expanding water from flowing back into the main supply line, and the result of the "thermal expansion" can create a rapid and dangerous pressure increase in the water heater and system piping. This rapid pressure increase can quickly reach the safety setting of the relief valve, causing it to operate during each heating cycle. Thermal expansion, and the resulting rapid and repeated expansion and contraction of components in the water heater and piping system can cause premature failure of the relief valve, and possibly the heater itself. Replacing the relief valve will not correct the problem.

The suggested method of controlling thermal expansion is to install an expansion tank in the cold water line between the water heater and the check valve (refer to the illustration below). The expansion tank is designed with an air cushion built in that compresses as the system pressure increases, thereby relieving the over pressure condition and eliminating the repeated operation of the relief valve. Other methods of controlling thermal expansion are also available. Contact your installing contractor, water supplier, or plumbing inspector for additional information regarding this subject.

2.4 Water Supply Connections

Refer to the illustration below for a suggested typical installation. The installation of unions or flexible copper connectors is recommended on the hot and cold water connections so that the water heater may be easily disconnected for servicing if necessary. The HOT and COLD water connections are clearly marked and are 3/4" NPT on all models. Install a shut-off valve in the cold water line near the water heater.

2.5 Typical Installation

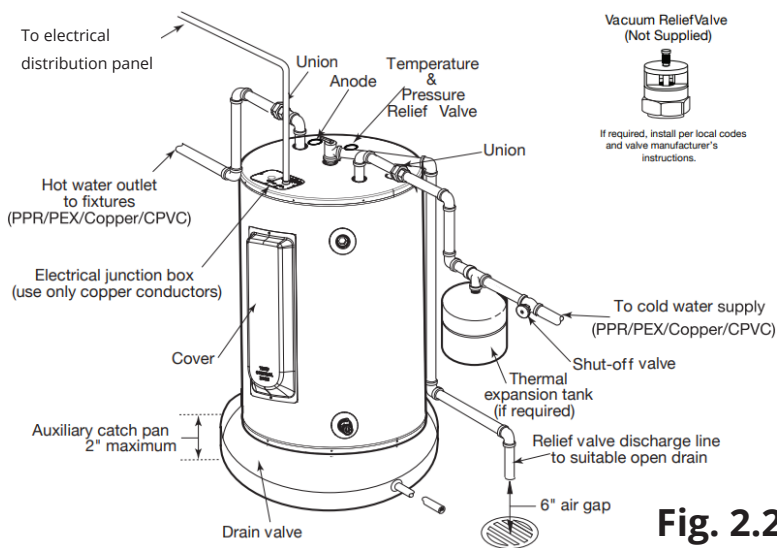

Fig. 2.2

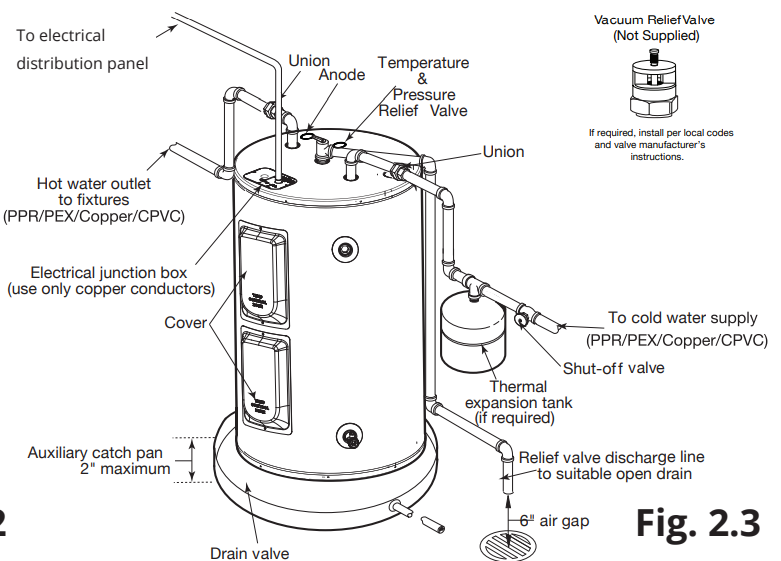

Fig. 2.3

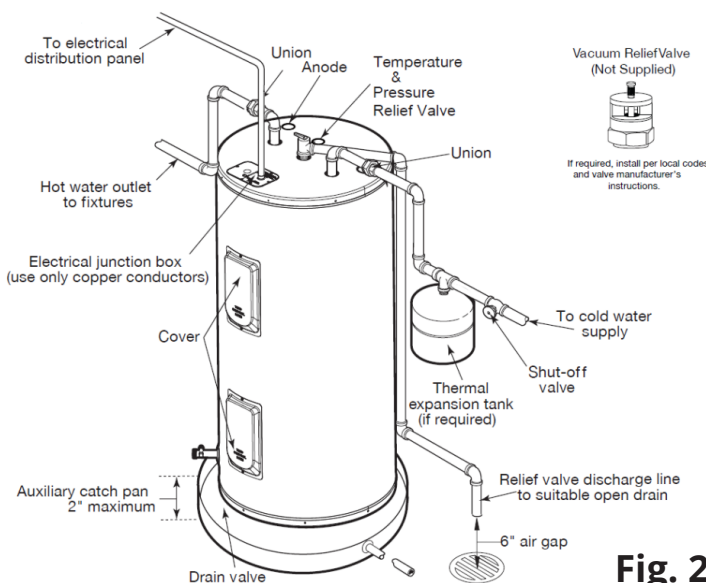

Fig. 2.4

NOTE: Do not apply heat to the hot and cold water connections. If sweat connections are used, sweat tubing to the adapter before fitting the adapter to the water connections on the heater. Any heat applied to the water supply fittings will permanently damage the dip tube and/or heat traps.

CAUTION

To reduce the risk of excessive pressures and temperatures in this water heater, install temperature and pressure protective equipment as required by local codes and no less than a combination temperature and pressure relief valve certified by a nationally recognized testing laboratory that maintains periodic inspection of production of listed equipment or materials, as meeting the requirements for Relief Valves and Automatic Gas Shutoff Devices for Hot Water Supply Systems, ANSI Z21.22. This valve must be marked with a maximum set pressure not to exceed the marked maximum working pressure of the water heater. Install the valve into an opening provided and marked for this purpose in the water heater. Orient the piping so that any water exiting the valve is no higher than 6 inches above the floor and does not contact any live electrical part. The discharge opening must not be blocked or reduced in size under any circumstances.

2.6 Relief Valve

The BTU/h rating of the relief valve must not be less than the input rating on the water heater as indicated on the rating label located on the front of the heater (1 watt = 3.412 BTU/h).

Connect the outlet of the relief valve to a suitable open drain so that the discharge water cannot contact live electrical parts or persons and to eliminate potential water damage.

Piping used should be of a type approved for hot water distribution. The discharge line must be no smaller than the outlet of the valve and must pitch downward from the valve to allow complete drainage (by gravity) of the relief valve and discharge line.

WARNING

The pressure rating of the relief valve must not exceed 150 PSI, the maximum working pressure of the water heater as marked on the rating plate.

2.7 Filling the Water Heater

Make certain the drain valve on the water heater is completely closed. Open the shut-off valve in the cold water supply line. Open each hot water faucet slowly to allow the air to vent from the water heater and piping.

A steady flow of water from the hot water faucet(s) indicates a full water heater.

WARNING

Do not turn on the electrical supply or operate this water heater unless it is completely full of water. The tank must be full of water before the heater is turned on. The water heater warranty does not cover damage or failure resulting from operation with an empty or partially empty tank.

2.8 Condensation

Condensation can form on the tank when it is first filled with water. Condensation might also occur with a heavy water draw and very cold inlet water. This condition is not unusual, and will disappear after the water becomes heated. If, however, the condensation continues, examine the piping and fittings for possible leaks.

2.9 Energy Cover

Items Required (Included and only required with Low Boy):

- Water Heater Energy Cover Side (insulation)
- Water Heater Energy Cover Top (insulation)
- Tape Strips

! CAUTION

Avoid contact with eyes and skin. Wear long sleeved, loose fitting clothing, gloves, and eye protection when handling fiberglass. Wash with soap and warm water after handling.

1. Wrap the cover around the water heater as shown in figure 2.5, pay attention to the hole positions of the cover and the corresponding installation positions of the valve bodies on the water heater.
2. Apply 4 pieces of tape strips across the water heater energy cover side as shown in figure 2.6.
3. Press down the covers top until it laps over the upper end of the cover side as shown in figure 2.7.
4. Cut the remaining tape strips short with scissors and secure the top insulation to the cover by using 4 tape strips that are 7 in (17.78 cm) long as shown in figure 2.8.

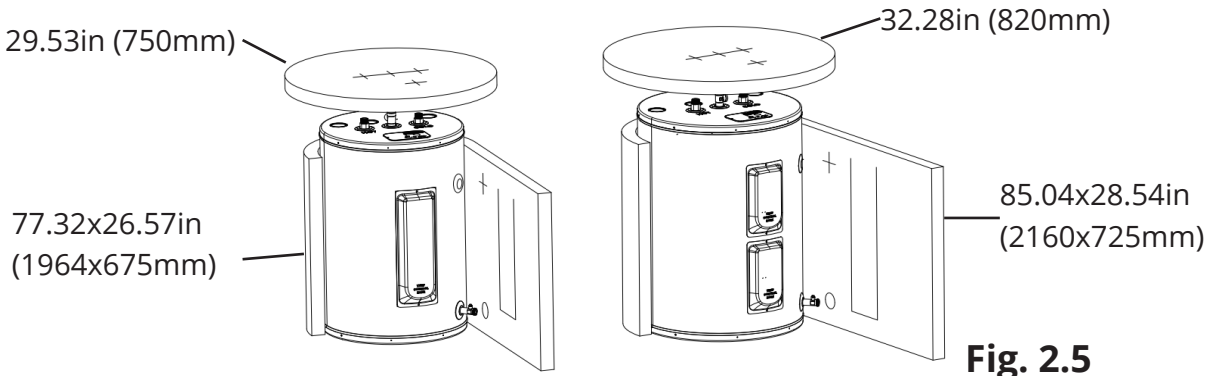

Fig. 2.5

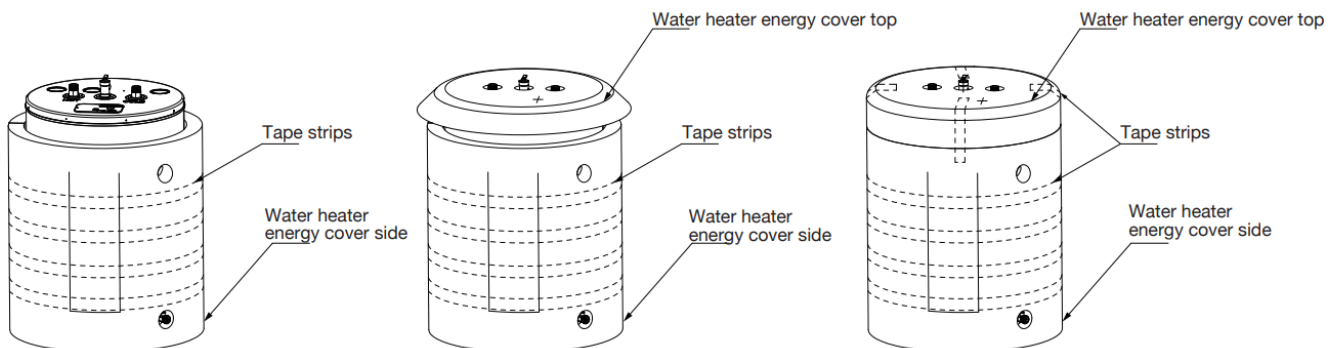

Fig. 2.6

Fig. 2.7

Fig. 2.8

2.10 Electrical Connections

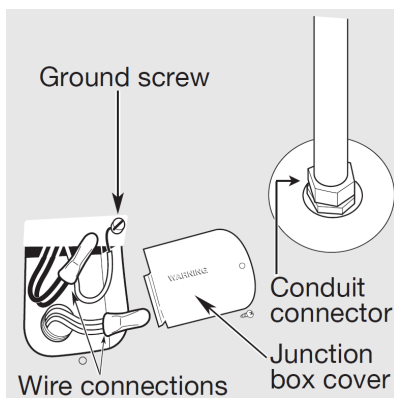

Fig. 2.9

A separate branch circuit with copper conductors, over-current protective device and suitable disconnecting means must be provided by a qualified electrician.

All wiring must conform to local codes or the latest edition of National Electrical Code ANSI/NFPA 70.

The water heater is completely wired to the junction box inside the jacket at the top front of the water heater. An opening for 1/2" or 3/4" electrical fitting is provided for field wiring connections. The voltage requirements and wattage load for the water heater are specified on the rating plate on the front of the water heater.

Connect the ground wire to the green ground screw.

To provide continued protection against risk of electrical shock, connect to a properly grounded circuit that is protected by a recognized Class A Ground-Fault Circuit Interrupter (GFCI).

2 INSTALLATION

The branch circuit wiring should include either:

1. Metallic conduit or metallic sheathed cable approved for use as a grounding conductor and installed with fittings approved for this purpose.
2. Non-metallic sheathed cable, metallic conduit, or metallic sheathed cable not approved for use as a ground connector shall include a separate conductor for grounding. It should be attached to the ground terminals of the water heater and the electrical distribution box.

! CAUTION

- The presence of water in the piping and water heater does not provide sufficient conduction for a ground. Non-metallic piping, dielectric unions, flexible connectors, etc. can cause the water heater to be electrically isolated.
- Do not turn on the electrical supply or operate this water heater unless it is completely full of water.
- This appliance must be connected to a grounded, metallic, permanent wiring system or an equipment-grounding conductor must be run with the circuit conductors and connected to the equipment-grounding terminal or lead on the unit.

Branch Circuit Sizing & Wire Size

NOTE: This guide recommends minimum branch circuit sizing and wire size based on the National Electric Code. Refer to the wiring diagrams in this manual for field wiring connections.

Total Water Heater Wattage	Recommended Over Current Protection (Fuse or Circuit Breaker Amperage Rating)		Copper Wire Size AWG Based on N.E.C. Table 310-16 (167°F / 75°C)	
	208V	240V	208V	240V
3,000	20	20	12	12
4,000	25	25	10	10
4,500	30	25	10	10
5,000	30	30	10	10
5,500	35	30	8	10

Technical Performance Parameters

Phase	1	1
Volts AC	240V	208V
Upper Element Watts	4500W	3380W
Lower Element Watts	4500W	3380W
Total Watts	4500W	3380W
Recommended Circuit Breaker	25A	20A
Protection Against Electric Shock: Class I		

2.11 Energy Efficiency

This water heater meets or exceeds the National Appliance Energy Conservation Act standards with respect to insulation and standby loss requirements when the energy cover is installed. The energy cover must be installed in accordance with the instructions provided.

2.12 Hot & Cold Pipe Insulation Installation

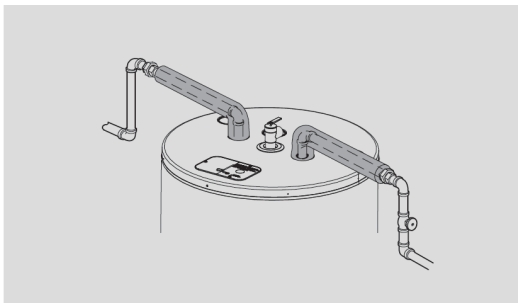

Fig. 2.10

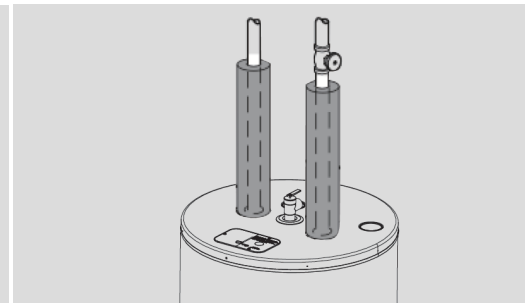

Fig. 2.11

For increased energy efficiency, the water heater includes two 24" sections of pipe insulation. Please install the insulation, according to the illustrations above, that best meets your requirements.

2.13 Relief Valve Insulation Installation

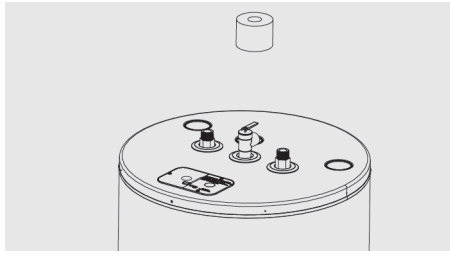

Fig. 2.12

For increased energy efficiency, some water heaters have been supplied with a 2-3/8" section of pipe insulation. Please install the insulation, according to the illustrations above, that best meets your requirements.

! CAUTION

Ensure the T&P valve opening is not obstructed by the insulation.

3.1 Installation Checklist

A. Water Heater Locations

- Close to the area of heated water demand.
- Unit is indoors and protected from freezing temperatures.
- Area is free of flammable vapors.
- Provisions are made to protect the area from water damage.

B. Water Supply

- Water heater is completely filled with water.
- Air is purged from the water heater and piping.
- Water connections are tight and free of leaks.

C. Relief Valve

- Temperature and Pressure Relief Valve is properly installed and the discharge line allows for proper drainage.
- The discharge line is protected from freezing.

D. Wiring

- Power Supply voltage agrees with water heater rating plate.
- Branch circuit wire and fusing or circuit breaker of proper size.
- Electrical connections are tight and the unit is properly grounded.
- Verify and check electrical grounding. Refer to page 12.

3.2 Operating the Water Heater

! CAUTION

Hydrogen gas can be produced in a hot water system served by this water heater that has not been used for a long period of time (generally two weeks or more). Hydrogen gas is extremely flammable! To dissipate such gas and to reduce risk of injury, it is recommended that the hot water faucet be opened for several minutes at the kitchen sink before using any electrical appliance connected to the hot water system. If hydrogen is present, there will be an unusual sound such as air escaping through the pipe as the water begins to flow. Do not smoke or use an open flame near the faucet at the time it is open.

Safety Precautions

- A. Turn off power to the water heater if it has been subjected to overheating, fire, flood, or physical damage.
- B. Do NOT turn on the water heater unless it is filled with water.
- C. DO NOT turn on the water heater if the cold water supply shut-off valve is closed.
- D. If there is any difficulty in understanding or following the operating or maintenance instructions within this manual, it is recommended that a qualified person or service person perform the work.

Safety Controls

The water heater is equipped with a combination thermostat and temperature limiting control (ECO) that is located above the heating element in contact with the tank surface. If for any reason the water temperature becomes excessively high, the temperature limiting control (ECO) breaks the power circuit to the heating element. Once the control opens, it must be reset manually.

1. Turn off the power to the water heater.
2. Remove the jacket access panel(s) and insulation. The thermostat protective cover should not be removed.
3. Press the red RESET button.
4. Replace the insulation and jacket access panel(s) before turning on the power to the water heater.

3 POST-INSTALLATION

! WARNING

If the water heater has been subjected to flood, fire, or physical damage, turn off power and water to the water heater. Do not operate the water heater again until it has been thoroughly checked by qualified service personnel.

3.3 Water Temperature Settings

The temperature of the water in the water heater can be regulated by setting the temperature dial of the adjustable surface mounted thermostat(s) located behind jacket access panel(s).

Dual element heaters have two thermostats.

Safety and energy conservation are factors to be considered when selecting the water temperature setting of the water heater's thermostat(s). The lower the temperature setting, the greater the savings in energy and operating costs.

To comply with safety regulations, the thermostat(s) are factory set at 120°F (49°C) or less where local codes require. This is the recommended starting point. The factory set temperature of this electric water heater is 125°F (52°C).

Water temperatures above 125°F (52°C) can cause severe burns or death from scalding.

Be sure to read and follow the warnings outlined in this manual and on the label on the water heater. This label is located on the water heater near the thermostat access panel.

Mixing valves are recommended for reducing the point of use water temperature by mixing hot and cold water in branch water lines. It is recommended that a mixing valve complying with the Standard for Temperature Actuated Mixing Valves for Hot Water Distribution Systems, ASSE 1017 be installed. Contact a licensed plumber or the local plumbing authority for further information.

If Adjustment is Necessary:

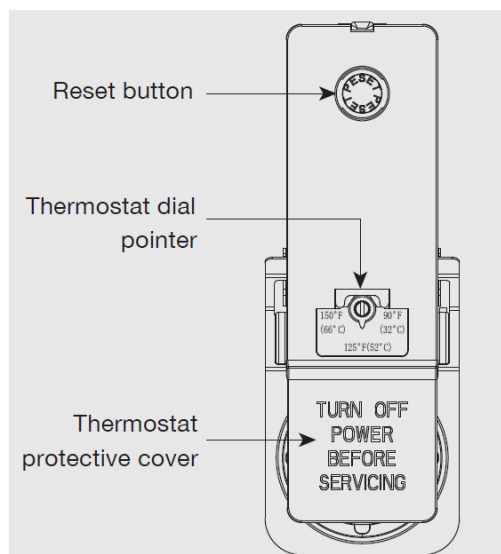

Fig. 3.1

! CAUTION

The cause of the high temperature condition must be investigated by a qualified service technician and corrective action must be taken before placing the water heater into service again.

! DANGER

- There is a hot water scald potential if the thermostat is set too high.
- Households with small children, disabled individuals, or elderly persons may require a 120°F (49°C) or lower thermostat setting to prevent contact with hot water.

Time/Temperature Relationship in Scalds

Temperature	Time to Produce a Serious Burn
120°F / 49°C	More than 5 minutes
125°F / 52°C	1.5-2 minutes
130°F / 54°C	About 30 seconds
135°F / 57°C	About 10 seconds
140°F / 60°C	Less than 5 seconds
145°F / 63°C	Less than 3 seconds

1. Turn off the power to the water heater.
2. Remove the jacket access panel(s) and insulation exposing the thermostat(s). The thermostat protective cover should not be removed.
3. Using a small screwdriver, set the thermostat(s) dial pointer(s) to the desired temperature.
4. Replace the insulation and jacket access panel(s). Turn on the power to the water heater.

3.4 Draining the Water Heater

In order to drain the water heater, turn off the cold water supply. Open a hot water faucet or lift the handle on the relief valve to admit air to the tank.

Attach a garden hose to the drain valve on the water heater and direct the stream of water to a drain. Open the valve.

! CAUTION

Shut off power to the water heater before draining water.

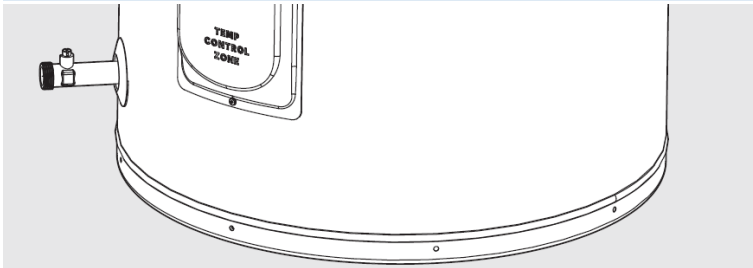

Fig. 3.2

3.5 Routine Preventative Maintenance

Properly maintained, your water heater will provide years of dependable, trouble-free service.

It is suggested that a routine, preventative maintenance program be established and followed by the user.

It is further recommended that a periodic inspection of the operating controls, heating element, and wiring should be made by service personnel qualified in electrical appliance repair.

Most electrical appliances, even when new, make some sound in operation. If the hissing or singing sound level increases excessively, the electric heating element may require cleaning. Contact a qualified installer or plumbing contractor to inspect.

At least once a year, lift and release the lever handle on the temperature pressure relief valve, located near the top of the water heater, to make certain the valve operates freely. Allow several gallons to flush through the discharge line to an open drain.

A water heater's tank can act as a setting basin for solids suspended in the water. It is therefore not uncommon for hard water deposits to accumulate in the bottom of the tank. It is suggested that a few quarts of water be drained from the water heater's tank every month to clean the tank of these deposits.

Rapid closing of faucets or solenoid valves in automatic water-using appliances can cause a banging noise heard in a water pipe. Strategically located risers in the water pipe system or water hammer arresting devices can be used to minimize the problem.

The anode rod should be removed from the water heater's tank annually for inspection and replaced when more than 6" of core wire is exposed at either end of the rod.

Make sure the cold water supply is turned off before removing the anode rod.

NOTE: If the temperature and pressure relief valve on the hot water heater discharges periodically, this may be due to thermal expansion in a closed water system. Contact the water supplier or your plumbing contractor on how to correct this. Do not plug the relief valve outlet.

3.6 Extended Shut Down

If the water heater is to remain idle for an extended period of time, the power and water to the appliance should be turned off to conserve energy and prevent a build-up of dangerous hydrogen gas.

The water heater and piping should be drained if they might be subjected to freezing temperatures.

After a long shut-down period, the water heater's operation and controls should be checked by qualified service personnel. Make certain the water heater is completely filled again before placing it in operation.

NOTE: Refer to the Hydrogen Gas caution in "3.2 Operating the Water Heater".

3.7 Anode Rod

This water heater is equipped with an anode rod designed to prolong the life of the glass lined tank. The anode rod is slowly consumed, thereby eliminating or minimizing corrosion of the glass-lined tank.

Water sometimes contains a high sulfate and/or mineral content and together with cathodic protection processes can produce a hydrogen sulfide, or rotten egg odor in the heated water. Chlorination of the water supply should minimize the problem.

NOTE: Do NOT remove the anode rod from the water heater's tank, except for inspection and/or replacement, as operation with the anode rod removed will greatly shorten the life of the glass lined tank and will exclude warranty coverage.

3 POST-INSTALLATION

3.8 Grounding

! WARNING

Improper grounding can result in serious injury or death from electric shock. This water heater must be properly grounded in accordance with the National Electrical Code (NEC) and all local electrical codes. Failure to provide proper grounding may result in electric shock, equipment failure, or fire.

1. **Purpose of Grounding** - This water heater must be grounded to ensure user safety and to allow proper operation of overcurrent protection devices. Grounding provides a low-resistance path to carry away fault current in the event of a short circuit or insulation failure.
2. **Before Installation: Verify Grounding** - Disconnect the breaker and inspect the electrical connections in the old water heater. If damage to the wiring coming from the electrical panel is apparent, call an electrician before continuing. Damage could look like frayed wiring, insulation degradation, and failed electrical bushings. Once electrical connections are confirmed to be undamaged, disconnect the wiring and removed the old water heater.
 - **Continuity Test** - Connect the wiring from the panel box to the water heater. Then, using a multimeter, check for electrical continuity between the water heater's metal jacket (or ground terminal), the ground terminal screw located on the breaker panel (e.g., service panel ground bar or grounded outlet box). The resistance should be close to **0 ohms**. A high resistance indicates a faulty or broken ground. If broken, contact a qualified electrician for repair.
 - **Ground Loop Impedance Test** (if required by local code) - For professional verification, a loop impedance tester can be used to verify that the ground path has sufficiently low impedance allowing breakers to safely trip in fault conditions.
3. **During Installation:**
 - **Visual Inspection of Water Heater** - Confirm the green or bare copper grounding wire is securely connected to the heater's ground screw within the terminal box located on the top pan.
4. **After installation: Confirm Connection** - Ensure that all wire terminations are tight and corrosion-free. Do not paint over bonding or grounding points. Do not energize the unit until grounding is confirmed.

3.9 Troubleshooting

Review the following chart before calling for service.

Problem	Causes	What To Do
Rumbling Noise	Water conditions in your home caused a build-up of scale or mineral deposits on the heating elements.	Remove and clean the heating elements.
Relief valve producing popping noise or draining	Pressure build-up caused by thermal expansion in a closed system.	This is an unacceptable condition and must be corrected. Contact the water supplier or plumbing contractor on how to correct this. Do not plug the relief valve outlet.
Not enough or no hot water	Water usage may have exceeded the capacity of the water heater.	Wait for the water heater to recover after an abnormal demand.
	A fuse is blown or a circuit breaker tripped.	Replace fuse or reset circuit breaker.
	Electric supply may be off.	Make sure the electric supply to the water heater and disconnect switch, if used, are in the ON position.
	The thermostat may be set too low.	See the temperature regulation section of this manual.
	Leaking or open hot water faucets.	Make sure all faucets are closed.
	Electric service to your home may be interrupted.	Contact the local electric utility.
	Improper Wiring	See the installation section of this manual.
	Manual reset limit (ECO).	See the temperature regulation section of this manual.
Water is too hot	The thermostat is set too high.	This is normal. The colder inlet water takes longer to heat. See the temperature regulation section of this manual.

3.10 Replacement Parts

To order replacement parts, contact MRCOOL® tech support at <https://mrcool.com/contact> or call (270) 366-0457. Use the following diagram to identify the needed replacement parts.

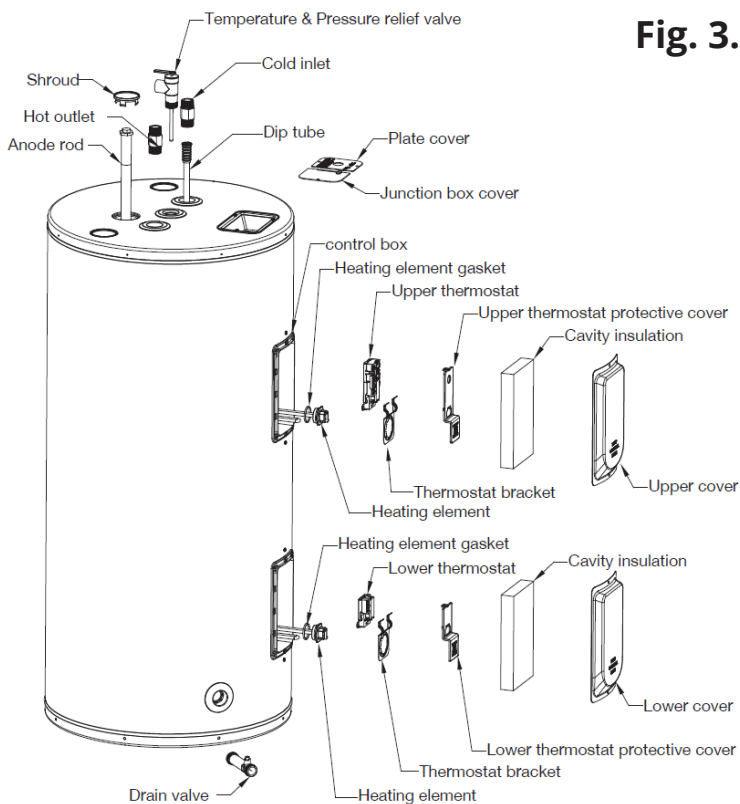

Fig. 3.3

Fig. 3.4

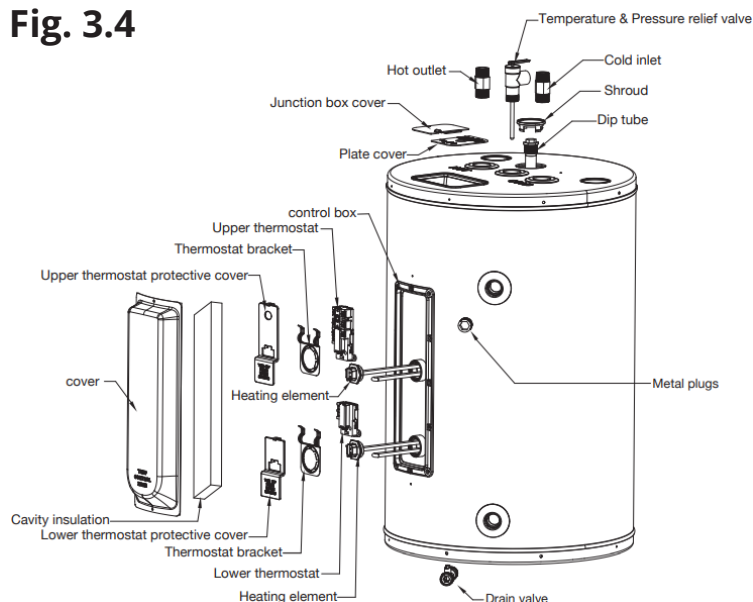
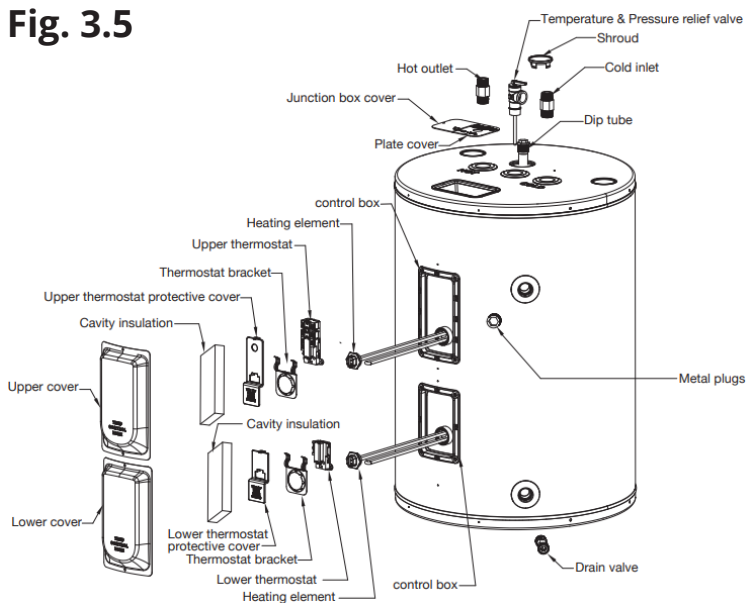

Fig. 3.5



! CAUTION

For your safety, **DO NOT** attempt the repair of electrical wiring, thermostats, heating elements, or other safety devices. Refer repairs to qualified service professionals.

3 POST-INSTALLATION

3.11 Service Needs

Should you have any questions about your new water heater, or if it requires adjustment, repair, or routine maintenance, it is suggested that you first contact your installer, plumbing contractor, or previously agreed upon service agency.

Should your problem not be solved to your complete satisfaction, contact MRCOOL® tech support at <https://mrcool.com/contact> or call (270) 366-0457.

When contacting contact MRCOOL® tech support, it is helpful to have the following information available:

- Model and serial number of the water heater as shown on the rating plate attached to the jacket of the heater.
- Address where the water heater is located and its physical location.
- Name and address of the installer and any service agency who performed service on the water heater.
- Date of original installation and dates any service work was performed.
- Details of the problems as you can best describe them.

3.12 Wiring Diagram

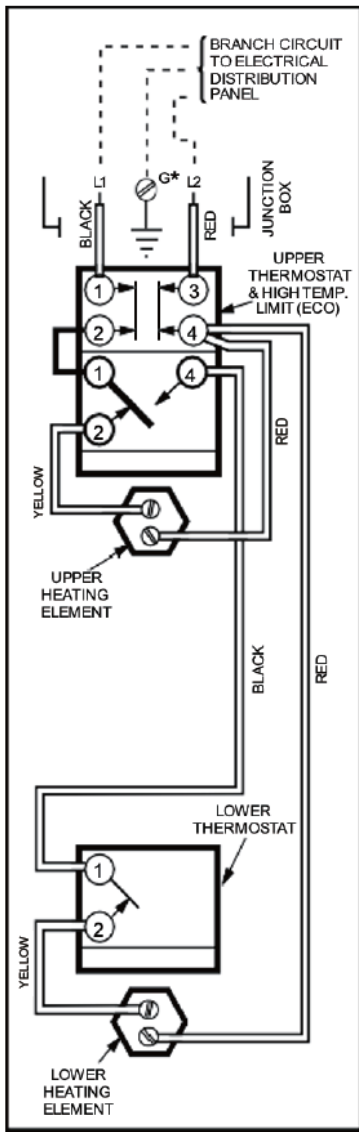

This electric water heater is wired as indicated below.

Double Element Non-Simultaneous

* Grounding conductor may be required. Refer to wiring section of this manual.

This water heater is factory equipped for two (2) wire connection to electrical power. For use with "off-peak" meter (timer), remove the wire nut from the red and black leads and connect to "off-peak" meter (timer).

Fig. 3.6



MRCOOL®
COMFORT MADE SIMPLE

HeatWise™

Electric Tank Water Heater

The design and specifications of this product and/or manual are subject to change without prior notice.
Consult with the sales agency or manufacturer for details.