

*This product utilizes R-454B refrigerant*

# MRCOOL®

## Pre-Charged Coil

### Service Manual

**MODELS:**  
**MCMP\*OTB**



Read this manual carefully before installation and keep it where the operator can easily find it for future reference.

Due to updates and constantly improving performance, the information and instructions within this manual are subject to change without notice.

Version Date: March 5, 2026  
Please visit [www.mrcool.com/documentation](http://www.mrcool.com/documentation)  
to ensure you have the latest version of this manual.



## CONTENTS

<b>1</b>	<b>SAFETY</b> .....	2
<b>2</b>	<b>SYSTEM OVERVIEW</b> .....	9
	2.1 System Introduction.....	9
	2.2 Dimensional Drawings.....	9
	2.3 Clearances .....	11
	2.4 Fan Performance .....	12
	2.5 Refrigerant Diagram .....	12
	2.6 Wiring Diagram.....	13
	2.7 DIP Switch Definitions.....	14
<b>3</b>	<b>INSTALLATION</b> .....	18
	3.1 Location Selection .....	18
	3.2 Indoor Unit Installation (A-COIL) .....	18
	3.3 Installation of MINI Interface.....	21
	3.4 Refrigerant Pipe Installation .....	22
	3.5 Insulation.....	23
	3.6 Electrical Wiring .....	34
<b>4</b>	<b>PRODUCT FEATURES</b> .....	26
	4.1 Wiring.....	26
	4.2 Controls .....	28
	4.3 Safety Features (NON-24V Control).....	30
<b>5</b>	<b>TROUBLESHOOTING</b> .....	33
	5.1 Safety Caution.....	33
	5.2 Error Display (Indoor Unit) .....	34
	5.3 Information Inquiry & Setting.....	35
	5.4 Error Diagnosis Without Error Code.....	40
	5.5 Quick Maintenance by Error Code .....	47
	5.6 Troubleshooting by Error Code .....	48
	5.7 Check Procedures.....	68
<b>6</b>	<b>TEMPERATURE SENSOR RESISTANCE TABLE</b> .....	69
<b>7</b>	<b>SYSTEM PRESSURE TABLE</b> .....	71

## Safety Precautions

### Read Before Using

Incorrect usage may cause serious damage or injury.

The symbols below are used throughout this manual to indicate instructions that should be followed closely or actions that should be avoided to prevent death, injury, and/or property damage.



Indicates the possibility of personal injury or loss of life.



Indicates the possibility of property damage or serious consequences.

### WARNING FOR PRODUCT INSTALLATION

**INSTALLATION MUST BE PERFORMED BY AN AUTHORIZED DEALER OR SPECIALIST. DEFECTIVE INSTALLATION CAN CAUSE WATER LEAKAGE, ELECTRICAL SHOCK, OR FIRE.**

**\*\*\*\*ELECTRICAL WORK MUST BE COMPLETED BY A QUALIFIED ELECTRICAL TECHNICIAN\*\*\*\***

**⚠ DO NOT** install the unit in a location that may be exposed to combustible gas leaks. If combustible gas accumulates around the unit, it could cause fire.

**⚠ DO NOT** turn on the power until the installation and all work has been completed.

1. Installation must be performed according to the installation instructions. Improper installation could cause water leakage, electrical shock, or fire.
2. Contact an authorized service technician for repair or maintenance of this unit.
3. This appliance must be installed in accordance with national wiring regulations.
4. Only use the included accessories, parts, and specified parts for installation. Using non-standard parts can cause water leakage, electrical shock, fire, and/or failure of the unit.
5. Install the unit in a firm location that can support the unit's weight. If the location cannot support the unit's weight, or the installation is not done properly, the unit may drop and cause serious injury and damage.
6. Install the drainage piping according to the instructions in this manual. Improper drainage could cause water damage to your home and/or property.
7. When moving or relocating the air conditioner, consult experienced service technicians for disconnection and re-installation of the unit.
8. For detailed information of how to install the indoor and outdoor units to their respective supports, please refer to the indoor unit installation and outdoor unit installation sections of this manual.
9. USB device access, replacement, and maintenance operations must be carried out by professional staff.

### WARNING FOR CLEANING & MAINTENANCE

1. **DO NOT** clean the unit with excessive amounts of water.
2. **DO NOT** clean the unit with combustible cleaning agents, as these could cause deformation and/or fire.
3. Turn off the device and disconnect the power before cleaning. Failure to do this could result in electrical shock.

### TAKE NOTE OF FUSE SPECIFICATIONS

- The unit's circuit board (PCB) is designed with a fuse to provide over-current protection.
- The specifications of the fuse are printed on the circuit board, examples of such are T5A/250VAC and T10A/250VAC.

**Note:** Only a blast-proof ceramic fuse can be used.



## WARNING FOR PRODUCT USE

- ⊘ **DO NOT** insert fingers, rods, or other objects into the air inlet or outlet. This could cause injury, since the fan may be rotating at high speeds.
  - ⊘ **DO NOT** use flammable sprays such as hair spray, lacquer or paint near the unit, as this could cause fire and/or an explosion.
  - ⊘ **DO NOT** operate the unit in places near or around combustible gases. Emitted gas may collect around the unit and cause an explosion.
  - ⊘ **DO NOT** allow children to play with the appliance. Children must be supervised around the unit at all times.
  - ⊘ **DO NOT** operate the unit in a room where it could be exposed to excessive amounts of water, such as a bathroom or laundry room. Exposure to excessive water amounts can cause the electrical components to short circuit.
  - ⊘ **DO NOT** expose your body directly to direct cool airflow from the unit for a prolonged period of time.
1. If the unit operates abnormally (emits strange noises or a burning smell), immediately turn off the unit and disconnect the power in order to avoid electric shock, fire, and/or injury. Call your local dealer, or MRCOOL® tech support at (270) 366-0457, for further assistance.
  2. If the air conditioner is used together with burners or other heating devices, thoroughly ventilate the room in order to avoid an oxygen deficiency.
  3. In certain functional environments (such as kitchens and server rooms etc.), the use of specially designed air-conditioning units is highly recommended.
  4. This appliance is not intended for use by persons (including children) with reduced physical, sensory or mental capabilities, or lack of experience and knowledge, unless they have been given supervision or instruction concerning use of the appliance by a person responsible for their safety. Children should be supervised to ensure that they do not play with the appliance.
  5. Turn off the unit and disconnect the power before performing any cleaning, installation, or repairing. Failure to do so can cause electric shock.



## CAUTION

- ⊘ **DO NOT** allow the air conditioner to operate for extended periods of time with the doors or windows open, or in very high humidity.
  - ⊘ **DO NOT** operate the air conditioner with wet hands, as this could cause electric shock.
  - ⊘ **DO NOT** use device for any other purpose than its intended use.
  - ⊘ **DO NOT** climb onto or place objects on top of the outdoor unit.
1. Make sure that water condensation can drain smoothly and unhindered from the unit.
  2. Turn off the unit and disconnect the power if the unit will not be used for an extended period of time.
  3. Turn off and unplug the unit during storms.



## ELECTRICAL WARNINGS

**\*\*\*\*ELECTRICAL WORK MUST BE COMPLETED BY A QUALIFIED ELECTRICAL TECHNICIAN\*\*\*\***

- ⊘ **DO NOT** share the power supply with other appliances. An improper or insufficient power supply could cause fire and/or electrical shock.
1. Only use the specified wire. If the wire is damaged, it must be replaced by the manufacturer, its service agent or similarly qualified persons in order to avoid a hazard.
  2. The product must be properly grounded during installation or electrical shock could occur.
  3. Appropriate wiring standards, regulations, and the installation manual must be followed for all electrical work.
  4. If connecting power to fixed wiring, an all-pole disconnection device must be incorporated in the fixed wiring in accordance with the wiring rules and must meet the following requirements: at least 3 mm of clearances in all poles, a leakage current that may exceed 10 mA, and a residual current device (RCD) having a rated residual operating current not exceeding 30 mA.
  5. Connect cables tightly and clamp them securely to prevent external forces from damaging the terminal.



## ELECTRICAL WARNINGS

- Improper electrical connections could overheat, causing fire and/or electrical shock.
5. All electrical connections must be made according to the Electrical Connection Diagram located on the panels of the indoor and outdoor units.
  6. All wiring must be properly arranged to ensure that the control board cover can close properly. If the control board cover is not properly closed, it can lead to corrosion and cause the connection points on the terminal to heat up, catch fire, or cause electrical shock.
  7. Disconnection must be incorporated in the fixed wiring in accordance with the wiring rules.



## FLAMMABLE REFRIGERANT WARNINGS

1. The installation of pipe-work should be kept to a minimum and should be protected from physical damage.
2. Refrigerant pipes should comply with national gas regulations.
3. All mechanical connections and ventilation openings should be kept clear of obstruction.
4. Utilize proper disposal processes based on national regulations.
5. Any person involved with working on or breaking into a refrigerant circuit should hold a current valid certificate from an industry-accredited assessment authority, which authorizes their competence to handle refrigerants safely in accordance with an industry recognized assessment specification.
6. Maintenance and repair requiring the assistance of other skilled personnel shall be carried out under the supervision of the person competent in the use of flammable refrigerants.
7. Do not use any means to accelerate the defrosting process or to clean, other than those recommended by the manufacturer.
8. The appliance shall be stored in a room without continuously operating ignition sources (for example: open flames, an operating gas appliance, or an operating electric heater).
9. Do not allow foreign matter (oil, water, etc.) to enter the piping, and securely seal the opening by pinching, taping, etc.
10. Do not pierce or burn.
11. Refrigerants may not contain an odor.
12. Working procedures that affect safety should only be carried out by competent persons.
13. The unit should be stored in a well-ventilated area where the room size corresponds to the room area as specific for operation, and should be stored so as to prevent potential mechanical damage from occurring.
14. Joints should be tested with detection equipment with a capability of 5 g/year of refrigerant or better, with the equipment in standstill and under operation or under a pressure of at least these standstill or operation conditions after installation. Detachable joints should NOT be used in the indoor side of the unit (brazed, welded joint could be used).
15. A leak detection system is installed. The unit must be powered except for service. For units with a refrigerant sensor, the indoor unit will display an error code and emit a buzzing sound, the compressor of the outdoor unit will immediately stop, and the indoor fan will start running. The service life of the refrigerant sensor is 15 years. When the refrigerant sensor malfunctions, the indoor unit will display the error code "FHCC". The refrigerant sensor cannot be repaired and can only be replaced by the manufacturer. It should only be replaced with the sensor specified by the manufacturer.
16. When a flammable refrigerant is used, the requirements for installation space of the appliance and/or ventilation requirements are determined according to:
  - The mass charge amount (M) used in the unit.
  - The installation location.
  - The type of ventilation of the location of the unit.
  - Piping material, pipe routing, and installation must include protection from physical damage in operation and service. This must be in compliance with local codes and standards, such as ASHRAE 15, IAPMO Uniform Mechanical Code, ICC International Mechanical Code, or CSA B52. All field joints must be accessible for inspection prior to being covered or enclosed.
  - Protection devices, piping and fittings must be protected as much as possible against adverse environmental effects. For example, against the danger of water collecting and freezing in relief pipes or against accumulation of dirt or debris.



## FLAMMABLE REFRIGERANT WARNINGS

- Piping in refrigeration systems must be designed and installed to minimize the likelihood of hydraulic shock, resulting in damage from the system.
  - Steel pipes and components must be protected against corrosion with a rust-proof coating before applying insulation.
  - Precautions must be taken against excessive vibration or movement of the unit.
  - The minimum floor area of the room must be mentioned in the form of a table or a single figure without reference to a formula.
17. After completion of field piping for split systems, the field pipework should be pressure tested with an inert gas and then vacuum tested prior to refrigerant charging, according to the following requirements:
    - The minimum test pressure for the low side of the system should be the low side design pressure and the minimum test pressure for the high side of the system should be the high side design pressure, unless the high side of the system cannot be isolated from the low side of the system in which case the entire system should not be pressure tested to the low side design pressure.
    - The test pressure after removal of pressure source shall be maintained for at least 1 hour with no decrease of pressure indicated by the test gauge, with test gauge resolution not exceeding 5% of the test pressure.
  18. Prior to beginning work on systems containing flammable refrigerants, safety checks are necessary to ensure that the risk of ignition is minimized. For repairs to the refrigerating system, the following precautions shall be complied with prior to conducting work on the system.
  19. Work should be undertaken under a controlled procedure so as to minimize the risk of a flammable gas or vapor being present while the work is being performed.
  20. All maintenance staff and others working in the local area should be instructed on the nature of work being carried out. Avoid work in confined spaces.
  21. The area should be checked with an appropriate refrigerant detector prior to and during work, to ensure the technician is aware of potentially flammable atmospheres. Ensure that the leak detection equipment being used is suitable for use with flammable refrigerants, i.e. no sparking, adequately sealed, or intrinsically safe.
  22. If any hot work is to be conducted on the refrigeration equipment or any associated parts, appropriate fire extinguishing equipment should be on site and readily available. Have a dry power or CO2 fire extinguisher adjacent to the charging area.
  23. No person carrying out work in relation to a refrigerating system which involves exposing any pipe work should use any sources of ignition in such a manner that it may lead to the risk of fire or explosion. All possible ignition sources, including cigarette smoking, should be kept sufficiently far away from the site of installation, repairing, removing, and disposal, during which refrigerant can possibly be released to the surrounding space. Prior to work taking place, the area around the equipment is to be surveyed to make sure that there are no flammable hazards or ignition risks. "No Smoking" signs should be displayed.
  24. Ensure that the area is in the open or that it is adequately ventilated before breaking into the system or conducting any hot work. A degree of ventilation shall continue during the period that the work is carried out. The ventilation should safely disperse any released refrigerant and preferably expel it externally into the atmosphere.
  23. Where electrical components are being changed, they shall be fit for the purpose and to the correct specification. At all times the manufacturer's maintenance and service guidelines shall be followed. If in doubt, consult the manufacturer's technical department for assistance. The following checks should be applied to installations using flammable refrigerants:
    - the actual refrigerant charge is in accordance with the room size within which the refrigerant containing parts are installed;
    - the ventilation machinery and outlets are operating adequately and are not obstructed;
    - if an indirect refrigerating circuit is being used, the secondary circuits should be checked for the presence of refrigerant;
    - marking to the equipment continues to be visible and legible, marking and signs that are illegible should be corrected;
    - refrigerant pipe or components are installed in a position where they are unlikely to be exposed to any substance which may corrode refrigerant containing components, unless the components are constructed of materials which are inherently resistant to or protected against corrosion.



## FLAMMABLE REFRIGERANT WARNINGS

24. Repair and maintenance to electrical components shall include initial safety checks and component inspection procedures. If a fault exists that could compromise safety, then no electrical supply shall be connected to the circuit until it is satisfactorily dealt with. If the fault cannot be corrected immediately but it is necessary to continue operation, an adequate temporary solution should be used.
25. Initial safety checks should include:
  - that capacitors are discharged: this should be done in a safe manner to avoid the possibility of sparking;
  - that there are no live electrical components and wiring are exposed while charging, recovering, or purging the system;
  - that there is continuity of earth bonding.
26. Sealed electrical components should be replaced if damaged.
27. Intrinsically safe components should be replaced if damaged.
28. Check that wiring will not be subject to wear, corrosion, excessive pressure, vibration, sharp edges, or any other adverse environmental effects. The check shall also take into account the effects of aging or continual vibration from sources such as compressors or fans.
29. Under no circumstances should potential sources of ignition be used in the search for or detection of refrigerant leaks. A halide torch (or any other detector using a naked flame) should not be used. The following leak detection methods are deemed acceptable for refrigerant systems. Electronic leak detectors may be used to detect refrigerant leaks but, in the case of flammable refrigerants, the sensitivity may not be adequate, or may need re-calibration. (Detection equipment shall be calibrated in a refrigerant-free area.) Ensure that the detector is not a potential source of ignition and is suitable for the refrigerant used. Leak detection equipment shall be set at a percentage of the LFL of the refrigerant and should be calibrated to the refrigerant employed, and the appropriate percentage of gas (25% minimum) is confirmed. Leak detection fluids are also suitable for use with most refrigerants but the use of detergents containing chlorine may react with the refrigerant and corrode the copper work. Examples of leak detection fluids are the bubble method, fluorescent method agents, etc. If a leak is suspected, all naked flames should be removed/extinguished. If a leakage of refrigerant is found which requires brazing, all of the refrigerant should be recovered from the system, or isolated (by means of shut-off valves) in a part of the system remote from the leak. See the following instructions of removal of refrigerant.
30. When breaking into the refrigerant circuit to make repairs, or for any other purpose, conventional procedures should be used. However, for flammable refrigerants, it is even more vital to follow best practice. The following procedure should be adhered to:
  - safely remove refrigerant following local and national regulations;
  - evacuate;
  - purge the circuit with inert gas;
  - evacuate;
  - continuously flush or purge with inert gas when using flame to open circuit;
  - open the circuit
31. The refrigerant charge should be recovered into the correct recovery cylinders if venting is not allowed by local and national codes. For units containing flammable refrigerants, the system should be purged with oxygen-free nitrogen to render the appliance safe for flammable refrigerants. This process might need to be repeated several times. Compressed air or oxygen shall not be used for purging refrigerant systems. For appliances containing flammable refrigerants, refrigerant purging should be achieved by breaking the vacuum in the system with oxygen-free nitrogen and continuing to fill the working pressure is achieved, then venting to atmosphere, and finally pulling down to a vacuum. This process should be repeated until no refrigerant is within the system. When the final oxygen-free nitrogen charge is used, the system should be vented down to atmospheric pressure to enable work to take place. The outlet for the vacuum pump should not be close to any potential ignition sources, and ventilation should be available.
32. In addition to conventional charging procedures, the following requirements should be followed:
  - Work should be undertaken with appropriate tools only (in case of uncertainty, please consult the manufacturer of the tools for use with flammable refrigerants)
  - Ensure that contamination of different refrigerants does not occur when using charging equipment. Hoses or lines shall be as short as possible to minimize the amount of refrigerant contained in them.



## FLAMMABLE REFRIGERANT WARNINGS

- Ensure that the refrigeration system is grounded prior to charging the system with refrigerant.
  - Label the system when charging is complete (if not already).
  - Extreme care should be taken not to overfill the refrigeration system.
  - Prior to recharging the system, it should be pressure tested with oxygen-free nitrogen (OFN). The system should be leak-tested on completion of charging but prior to commissioning. A follow-up leak test shall be carried out prior to leaving the site.
33. Before carrying out this procedure, it is essential that the technician is completely familiar with the equipment and all its detail. It is good recommended practice that all refrigerants are recovered safely. Prior to the task being carried out, an oil and refrigerant sample should be taken in case analysis is required prior to re-use of recovered refrigerant. It is essential that electrical power is available before the task is commenced.
- a. Become familiar with the equipment and its operation.
  - b. Isolate the system electrically.
  - c. Before attempting the procedure ensure that:
    - mechanical handling equipment is available, if required, for handling refrigerant cylinders;
    - all personal protective equipment is available and being used correctly;
    - the recovery process is supervised at all times by a competent person;
    - recovery equipment and cylinders conform to the appropriate standards
- Pump down refrigerant system, if possible.
- e. If a vacuum is not possible, make a manifold so that refrigerant can be removed from various parts of the system.
  - f. Make sure that the cylinder is situated on the scales before recovery takes place.
  - g. Start the recovery machine and operate in accordance with instructions.
  - h. Do not overfill cylinders (no more than 80% volume liquid charge).
  - i. Do not exceed the maximum working pressure of the cylinder, even temporarily.
  - j. When the cylinders have been filled correctly and the process completed, make sure that the cylinders and equipment are removed from the site promptly and all isolation valves on the equipment are closed off.
  - k. Recovered refrigerant should not be charged into another refrigeration system unless it has been cleaned and checked.
34. Equipment shall be labeled stating that it has been decommissioned and emptied of refrigerant. The label should be dated and signed. For appliances containing flammable refrigerants, ensure that there are labels on the equipment stating the equipment contains flammable refrigerant.
35. When removing refrigerant from a system, either for servicing or decommissioning, it is good recommended practice that all refrigerants are removed safely. When transferring refrigerant into cylinders, ensure that only appropriate refrigerant recovery cylinders are employed. Ensure that the correct number of cylinders for holding the total system charge is available. All cylinders to be used should be designated for the recovered refrigerant and labeled for that refrigerant (i.e. special cylinders for the recovery of refrigerant). Cylinders shall be complete with pressure-relief valve and associated shut-off valves in good working order. Empty recovery cylinders are evacuated and, if possible, cooled before recovery occurs. The recovery equipment should be in good working order with a set of instructions concerning the equipment that is at hand and should be suitable for the recovery of the flammable refrigerant. If in doubt, the manufacturer should be consulted. In addition, a set of calibrated weighing scales should be available and in good working order. Hoses should be complete with leak-free disconnect couplings and in good condition. The recovered refrigerant should be processed according to local legislation in the correct recovery cylinder, and the relevant waste transfer note arranged. Do not mix refrigerants in recovery units and especially not in cylinders.
36. If compressors or compressor oils are to be removed, ensure that they have been evacuated to an acceptable level to make certain that flammable refrigerant does not remain within the lubricant. The compressor body should not be heated by an open flame or other ignition sources to accelerate this process. When oil is drained from a system, it should be carried out safely.
37. An unventilated area where the appliance using flammable refrigerants is installed should be constructed so that should any refrigerant leak, it will not stagnate so as to create a fire or explosion hazard. If appliances connected via an air duct system to one or more rooms below the ventilation requirements,



## FLAMMABLE REFRIGERANT WARNINGS

that room should never contain potential ignition sources. A flame-producing device may be installed in the space if the device is provided with an effective flame arrest. Auxiliary devices which may be a potential ignition source should not be installed in the duct work. Examples of such are hot surfaces with a temperature exceeding 1292°F (700°C) and electric switching devices. Only auxiliary devices (such as a certified heater kit) approved by the manufacturer or declared suitable with the refrigerant should be installed in connecting ductwork. False or drop ceilings may be used as a return air plenum if a refrigerant detection system is provided in the appliance and any external connections are also provided with a sensor immediately below the return air plenum duct joint. Refrigerant sensors for refrigerant detection systems should only be replaced with sensors specified by the manufacturer. A leak detection system is installed. The unit must be powered except for service.

38. Transport of equipment containing flammable refrigerants should comply with transportation regulations.
39. Marking of equipment using signs should comply with local regulations.
40. Disposal of equipment using flammable refrigerants should comply with national regulations.
41. Storage of equipment/appliances should be in accordance with the manufacturer's instructions.
42. Storage of packed (unsold) equipment should be constructed so that mechanical damage to the equipment inside the package will not cause a leak of the refrigerant charge. The maximum number of pieces of equipment permitted to be stored together will be determined by local regulations.
43. During the evacuation test, after achieving a vacuum level specified in the manual or less, the refrigeration system shall be isolated from the vacuum pump and the pressure shall not rise above 1500 microns within 10 minutes. The vacuum pressure level should be specified in the manual, and should be the lessor of 500 microns of the value required for compliance with national and local codes and standards, which may vary between residential, commercial, and industrial buildings.
  - Field-made refrigerant joints indoors should be tightness-tested according to the following requirements: the test method should have a sensitivity of 5 grams per year of refrigerant or better under a pressure of at least 0.25 times the maximum allowable pressure. No leak should be detected.
  - Any servicing should be performed only as recommended by MRCOOL®.
43. Any maintenance, service, or repair operations must be performed by qualified personnel. Every working procedure that affects safety should only be carried out by competent persons that are both trained and certified. The training of these procedures should be carried out by national training organizations or manufacturers that are accredited to teach the relevant national competency standards that may be set in legislation. All training should follow the ANNEX HH requirements of UL 60334-2-40 4th Edition.
 

Examples of such working procedures are:

  - breaking into a refrigerant circuit
  - opening of sealed components
  - opening of ventilated enclosures

### Symbols Displayed on Indoor & Outdoor Unit

	<b>WARNING</b>	This symbol shows that this appliance uses a flammable refrigerant. If the refrigerant is leaked and exposed to an external ignition source, there is a risk of fire.
	<b>CAUTION</b>	This symbol shows that the operation manual should be read carefully.
	<b>CAUTION</b>	This symbol shows that a service personnel should be handling this equipment with reference to the installation manual.
	<b>CAUTION</b>	
	<b>CAUTION</b>	This symbol shows that information is available such as the operating manual or installation manual.

# 2 SYSTEM OVERVIEW

## 2.1 System Introduction

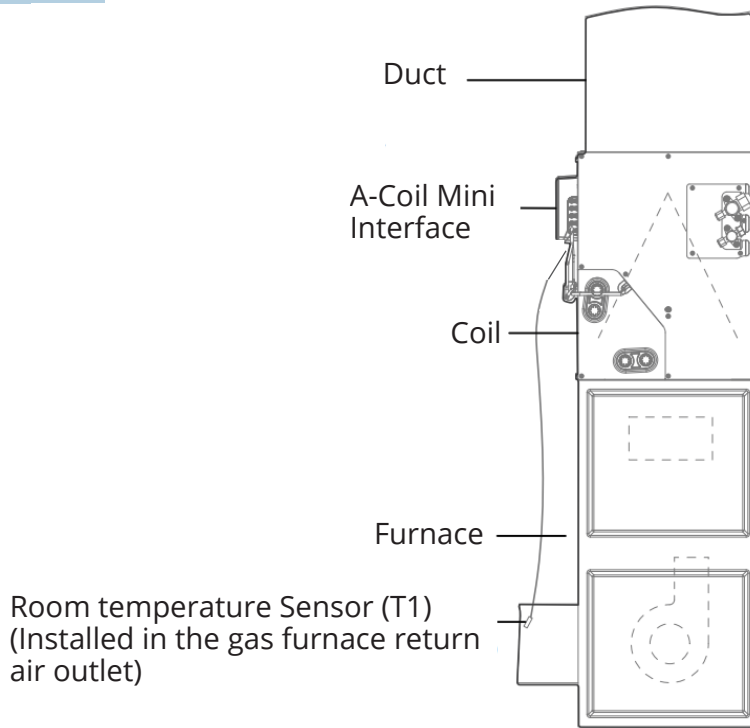

## 2.2 Dimensional Drawings

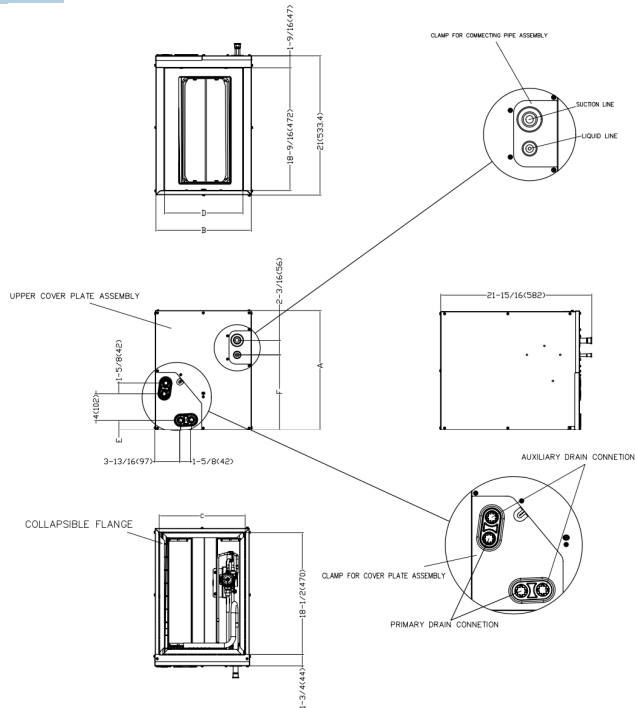

Model		MCMP-1824AOTB		MCMP-1824BTOPB		MCMP-3036BOTB		MCMP-4860DOTB	
Dimensions		inch	mm	inch	mm	inch	mm	inch	mm
A	Model Height	18	457	18	457	23-9/16	599	28	711
B	Model Width	14-1/2	368	17-1/2	445	17-1/2	445	24-1/2	622
C	Supply Air Opening Width	13-1/4	336	16-3/16	411	16-3/16	411	23-1/4	591
D	Return Air Opening Width	11-15/16	303	14-15/16	380	14-15/16	380	23-1/8	587
E	Condensate Drain Height	1-7/16	38	1-7/16	38	1-7/16	38	2-3/16	55
F	Liquid Line Height	11-3/8	290	11-3/8	290	16-3/8	417	21-7/16	545

## MCMP4860COTB

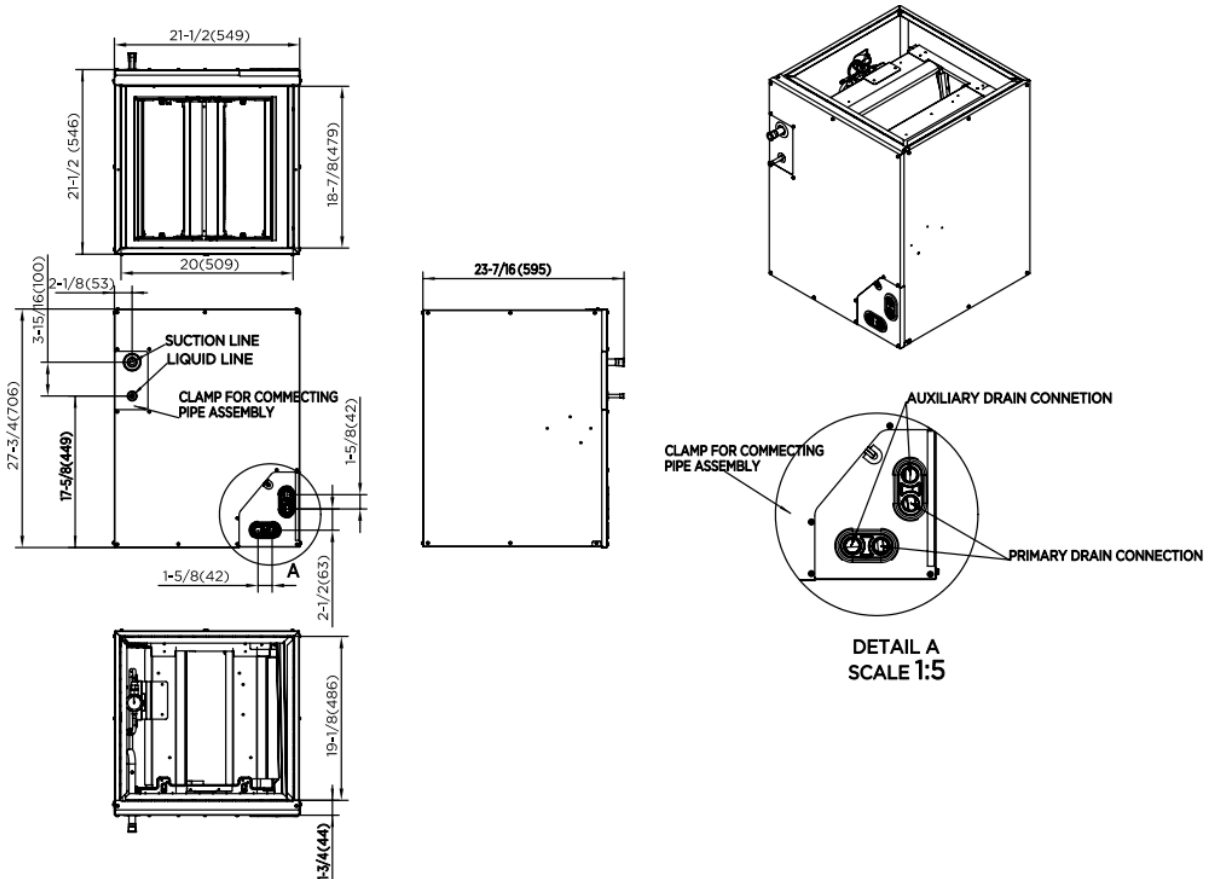

# 2 SYSTEM OVERVIEW

## 2.3 Clearances

Following clearances should be provided during installation.

- A. Maintenance and service access, including coil cleaning and coil assembly removal.
- B. Refrigerant piping and connections.
- C. Condensate drain line.

Ensure proper installation, place on a solid and level site.

Ensure there is enough space required for installation and maintenance.

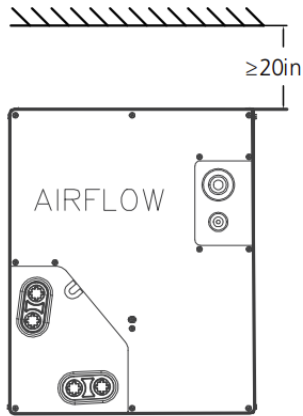

Front view of the indoor unit clearance (including air duct)

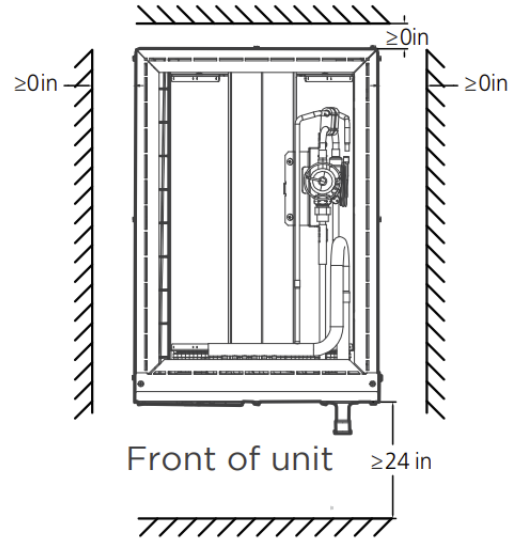

Top View of the indoor unit clearance (including air duct)

## 2.4 Fan Performance

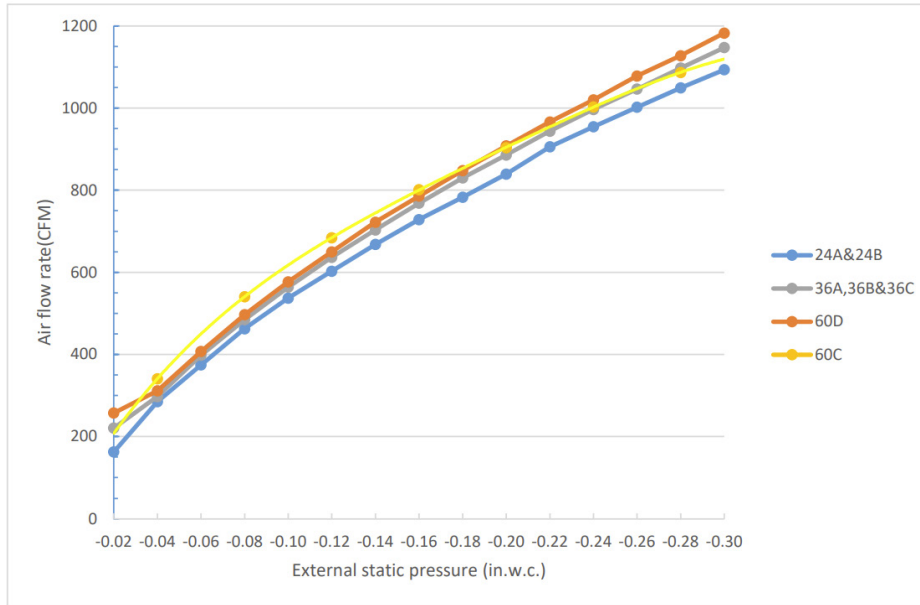



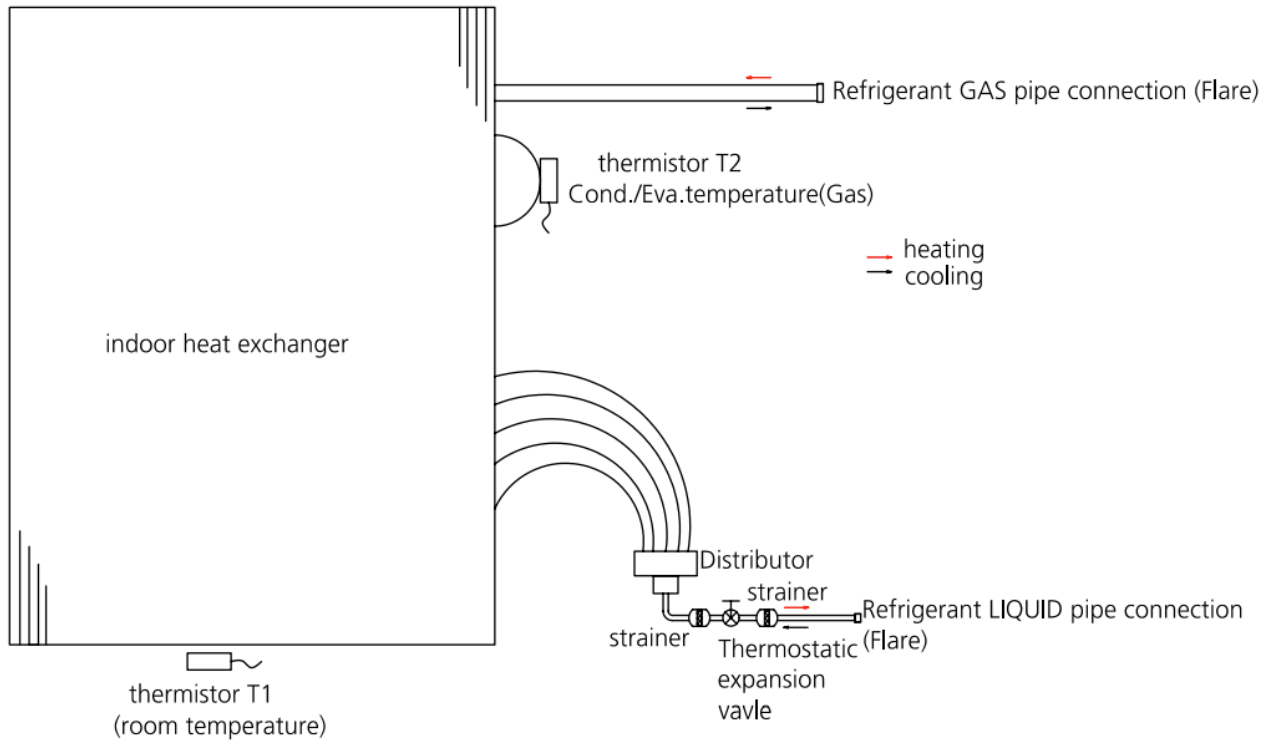

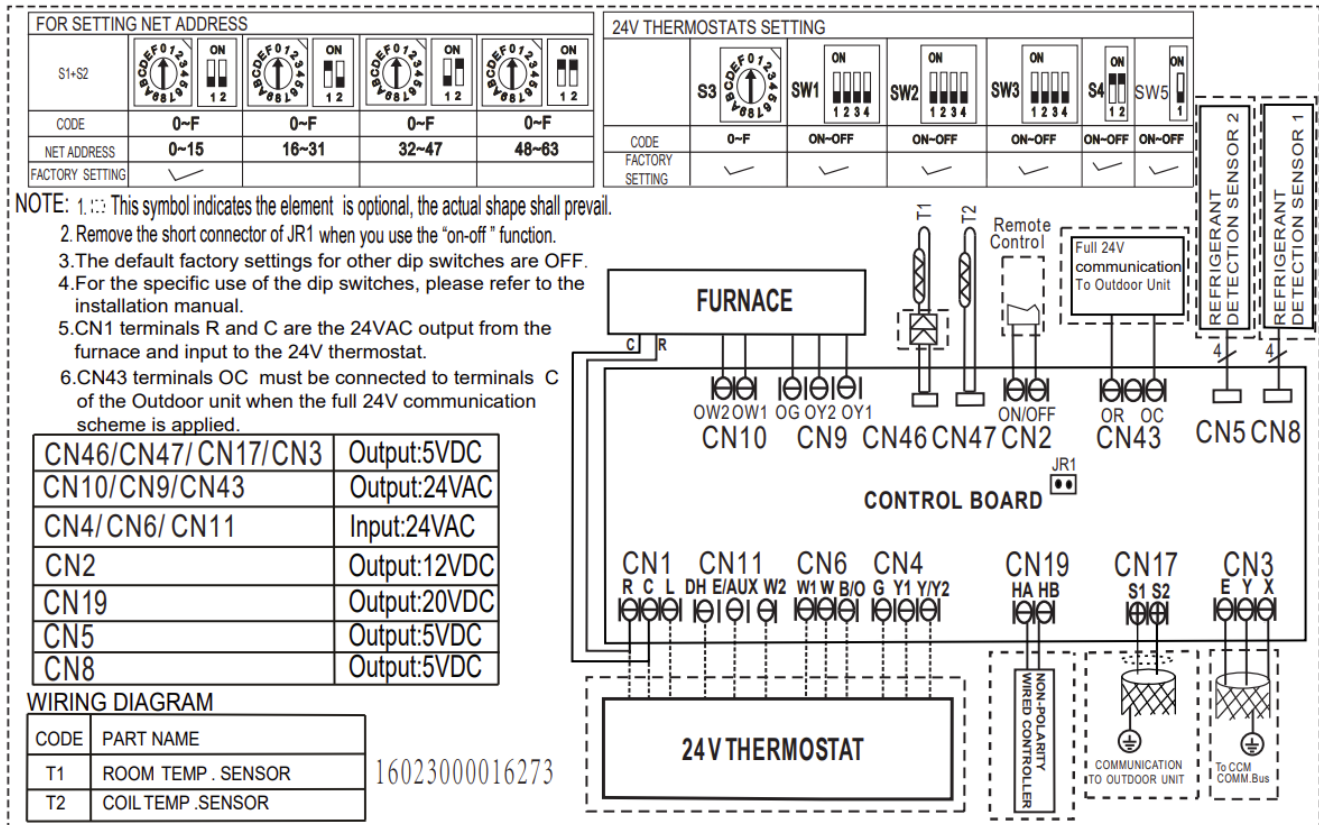

## 2.5 Refrigerant Diagram



## 2.6 Wiring Diagram





24V THERMOSTATS SETTING						
						
CODE	0~F	ON~OFF	ON~OFF	ON~OFF	ON~OFF	ON~OFF
FACTORY SETTING	✓	✓	✓	✓	✓	✓

## A. Function DIP Switch Settings

The 24V thermostat mode needs to refer to the following settings





No.	Dial Code	Function	ON	OFF ( Default)	Note	
<b>Scenario 1: 24V Tstat, S1+S2</b>						
1	SW1-2	Anti-cold blow protection option	No	(Default) Yes		
2	SW1-3	Single cooling/heating and cooling options	Cooling	(Default) Cooling & Heating		
3	SW2-4	Compressor	The operation of the heat pump is limited by the outdoor temperature, and the operation of auxiliary heat is not limited. The system makes judgments according to the following rules: 1) The compressor can be operated when the outdoor temperature is $\geq$ S3 DIP switch temperature $+2^{\circ}\text{C}$ . 2) The compressor cannot be operated when the outdoor temperature is lower than S3 DIP switch temperature.	[Default] The operation of the heat pump is limited by the outdoor temperature, and the operation of auxiliary heat is not limited. The system makes judgments based on the following rules: 1) The compressor cannot be operated when the outdoor temperature is lower than the S3 DIP switch. 2) The compressor can be operated when the outdoor temperature is $\geq$ S3 DIP switch temperature $+2^{\circ}\text{C}$ .	SW2-4 and S3 need to be working together	
4	Rotary Switch S3	Set outdoor temperature Limitation (for auxiliary heating or compressor)	Table A			
5	SW3-1	Maximum continuous runtime allowed before the system automatically stages up capacity to satisfy set point. This adds 1 to 5 °F to the user set point in the calculated control point to increase capacity and satisfy user set point.	30 minutes	[Default] 90 minutes		
6	SW3-2	Cooling and heating Y/ Y2 temperature differential adjustment.	Compressor slower speed	[Default] Faster Compressor	Only affects compressor	
7	S4-1	Default ON	[Default] For single stage supplemental heat, W1 and W2 are connected.	For dual stage supplemental heat, W1 and W2 are controlled independently.		
8	S4-2	DH function selection	[Default] Dehumidification control not available.	Dehumidification feature is enabled through the thermostat.		
9	SW5	Selection of the second Refrigerant Sensor	Both Refrigerant Sensor are used	Only use the first Refrigerant Sensor, interface is CN8		

No.	Dial Code	Function	ON	OFF ( Default)	Note
<b>Control Scenario</b>		<b>Scenario 2: Wired Controller: S1+S2</b>			
1	SW1-2	Anti-cold blow protection option	No	(Default) Yes	
2	SW1-3	Single cooling/heating and cooling options	Cooling	(Default) Cooling & Heating	
3	SW2-1	Temperature differential to active first stage furnace heating for HP+furnace mode	1°C	[Default] 2°C	
4	SW2-4	Compressor/Auxiliary heat outdoor ambient lockout	The operation of the heat pump is limited by the outdoor temperature, and the operation of auxiliary heat is not limited. The system makes judgments according to the following rules:1) The compressor can be operated when the outdoor temperature is $\geq$ S3 DIP switch temperature +2°C. 2) The compressor cannot be operated when the outdoor temperature is lower than S3 DIP switch temperature.	[Default] Only one heat pump or auxiliary heat can be operated. The system makes judgments according to the following rules: 1) When the outdoor temperature is lower than the S3 DIP switch temperature, the compressor is not allowed to be operated, but the auxiliary heat is allowed to operate; 2) When the outdoor temperature is $\geq$ S3 DIP switch temperature +2°C, the compressor can be operated, but the auxiliary heat cannot be operated.	SW2-4 and S3 need to be working together
5	Rotary Switch S3	Set outdoor temperature Limitation (for auxiliary heating or compressor)	Table A		
6	SW3-3	Temperature differential to active second stage furnace heating for furnace only or HP+furnace	3°C	[Default] 2°C	
7	SW5	Selection of the second Refrigerant Sensor	Both Refrigerant Sensor are used	Only use the first Refrigerant Sensor, interface is CN8	
<b>Control Scenario</b>		<b>Scenario 2: Wired Controller: S1+S2</b>			
1	SW1-3	Single cooling/heating and cooling options	Cooling	[Default] Cooling & Heating	
2	S4-1	Default ON	[Default] For single stage supplemental heat, W1 and W2 are connected.	For dual stage supplemental heat, W1 and W2 are controlled independently.	
3	S4-2	DH function selection	[Default] Dehumidification control not available	Dehumidification feature is enabled through the thermostat	
4	SW5	Selection of the second Refrigerant Sensor	Both Refrigerant Sensor are used	Only use the first Refrigerant Sensor, interface is CN8	

**Table A**

S3	S3 (°F)	S3 (°C)	S3	S3 (°F)	S3 (°C)
0	OFF	OFF	8	10	-12
1	-22	-30	9	18	-8
2	-18	-28	A	25	-4
3	-15	-26	B	32	0
4	-11	-24	C	36	2
5	-8	-22	D	39	4
6	-4	-20	E	43	6
7	3	-16	F	46	8

**Function Combination Table of SW1-1 and SW1-4**

SW1	Control type	IDU and ODU Connection	Note
	Wired controller / 24V thermostat	(S1+S2) / 24V connection	Auto Discovery
	Wired controller	S1+S2	Scenario 2
	24V Thermostat	S1+S2	Scenario 1
	24V Thermostat	24V connection	Scenario 3

## 3.1 Location Selection

### DO NOT install the unit in the following Locations:

- DO NOT install the indoor unit in a moist environment. Excessive moisture can corrode the equipment, electrical components, and cause electrical shorts.
- Areas with strong electromagnetic waves.
- Coastal areas with high salt content in the air.
- Areas with oil drilling or fracking.
- Areas that store flammable materials or gas.
- Areas where there may be detergent or other corrosive gases in the air, such as bathrooms, or laundry rooms.
- Areas where the air inlet and outlet may be obstructed.
- Danger of explosion. Keep flammable materials and vapors, such as gasoline, away from the air handler.

### WARNING: MUST BE INSTALLED IN A LOCATION THAT MEETS THE FOLLOWING REQUIREMENTS:



- ☑ Securely install the indoor unit on a structure that can support its weight. If the structure is too weak, the unit may fall and cause personal injury, unit and property damage, or death.

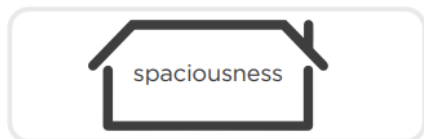

- ☑ Enough room for installation and maintenance.
- ☑ Enough room for the connecting pipe and drainpipe.



- ☑ Place air handler so that heating elements are at least 18in(460mm) above the floor for a garage installation. Failure to follow these instructions can result in death, explosion, or fire.

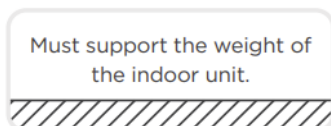

- ☑ The structure that the equipment is suspended from must support the weight of the indoor unit.

## 3.2 Indoor Unit Installation (A-COIL)

### Installation and Trap Connection:

1. See the following figure for the coil installation and drain connection.
2. Installation steps for cased coil:
  - A. Shut off or disconnect gas furnace's power and remove gas pipe if necessary.
  - B. Disconnect and remove a sufficient portion of the supply ductwork to provide clearance for the cased coil.
  - C. Ensure that the coil is leveled well and seal the gap between the coil and furnace. See Fig. 3-1. In case that the coil and furnace sizes are not matched, use the proper size of sheet metal or other material to fill the gap and seal the gap to prevent air leaks.
  - D. Reconnect the ductwork to the coil case, and seal any leakage.
  - E. Reconnect the power line on the gas furnace, turn on the furnace to check any sign of leakage.

### Typical Coil Installation on Furnace:

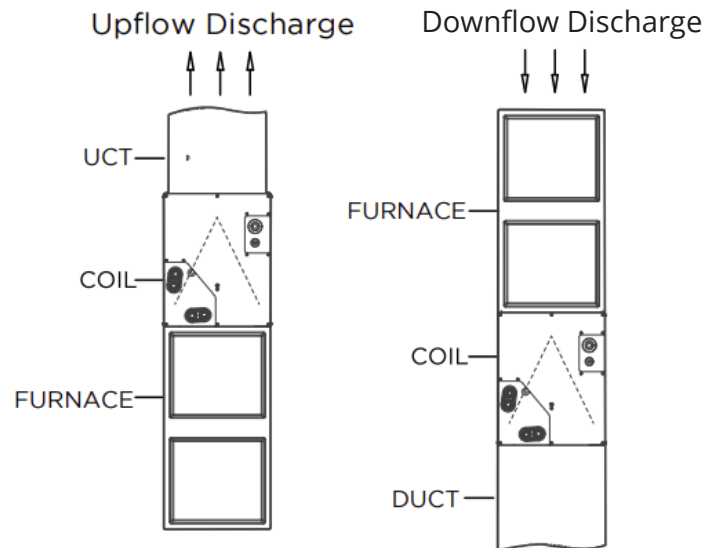

### Vertical Upflow & Downflow Installation

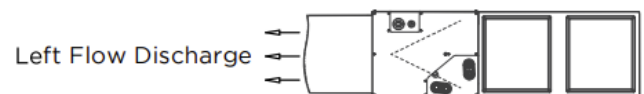
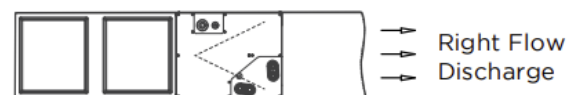

### Horizontal Right & Left Installation

# 3 INSTALLATION

## Model MVBM-60C28T6N10 coil installation on furnace

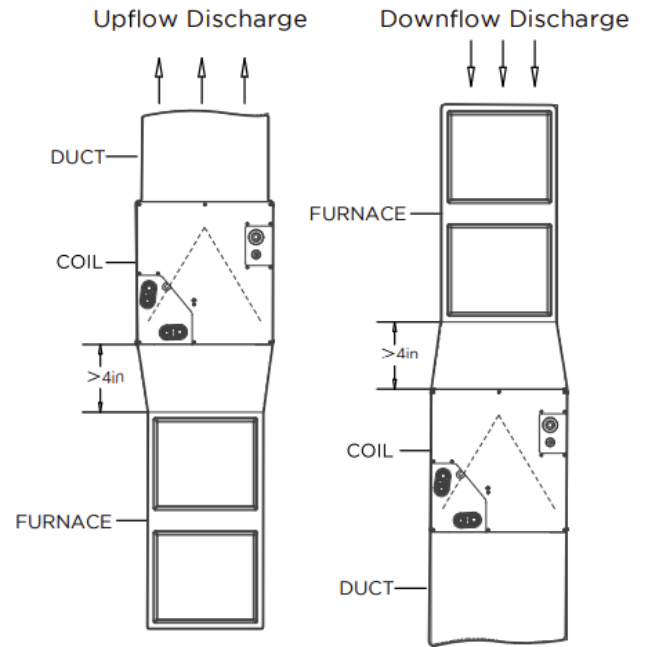
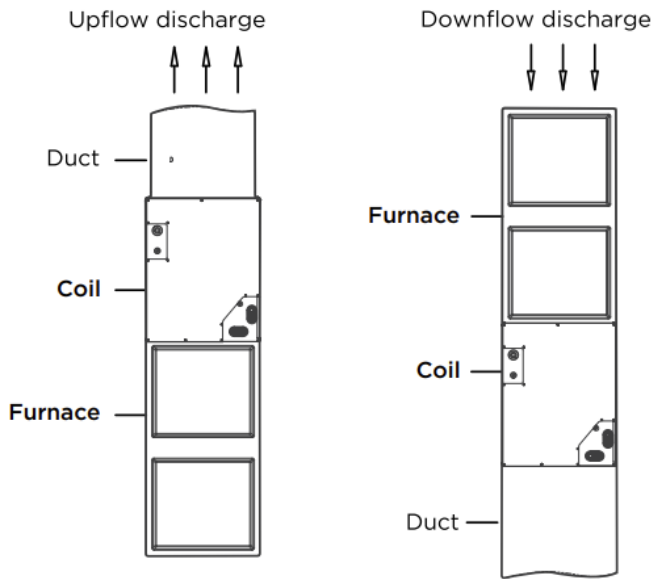

Vertical Upflow & Downflow Installation

Vertical Upflow & Downflow Installation Adapter(s) Installation When Coil Overhangs Furnace

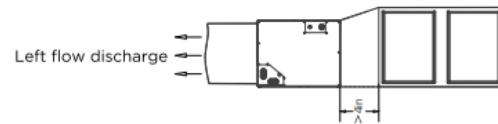
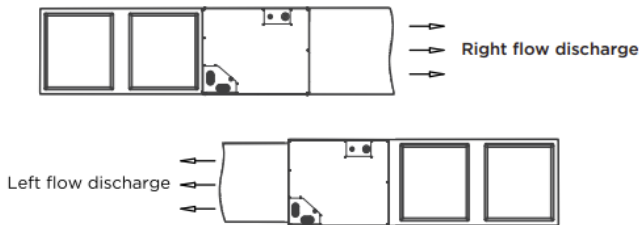

Horizontal Right & Left Installation

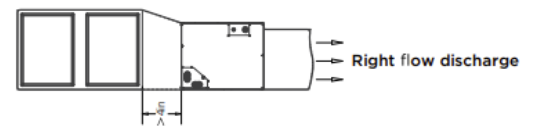

### Upflow Coil Installation:

The cased coil is designed to fit furnaces of the same width.

1. Set the coil in place on a upflow furnaces discharge air opening.
2. Ensure the coil is level for proper condensate drainage. Do not tip the coil toward the condensate drain. The coil casing does not need to be fastened or screwed to the furnace.
3. When installing a wider coil and a narrow furnace, create a field fabricated adapter.

Horizontal Right & Left Installation

Upflow discharge Downflow discharge

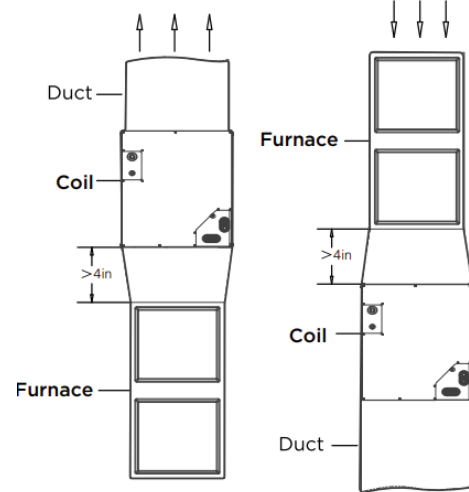
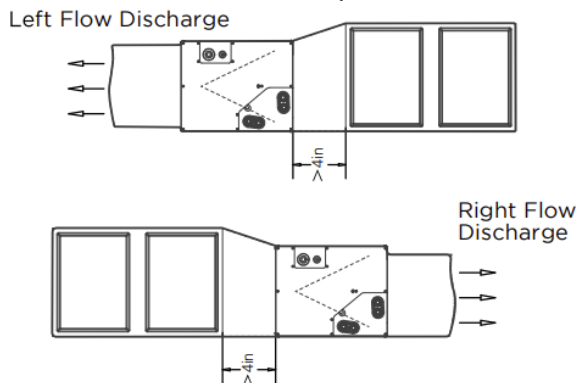

Vertical Upflow & Downflow Installation

Horizontal Right & Left Installation

Adapter(s) installation when Model MVBM-60C28T6N10 coil overhangs furnace

NOTE: On upflow installations where the indoor coil is placed in an unconditioned space, a 6" wide piece of insulation should be applied and wrapped around the outside of the coil casing and supply duct contact point.

NOTE: Consult the furnace installation instructions for any special requirements when installing the coil to the furnace.

### Downflow Coil Installation:

IMPORTANT: if the airflow is high due to ductwork or other causes, and there is a chance for water blow off, it is recommended that a 4-in. minimum field-supplied adapter be placed between the coil and the furnace to allow the air to distribute evenly to both coil slabs.

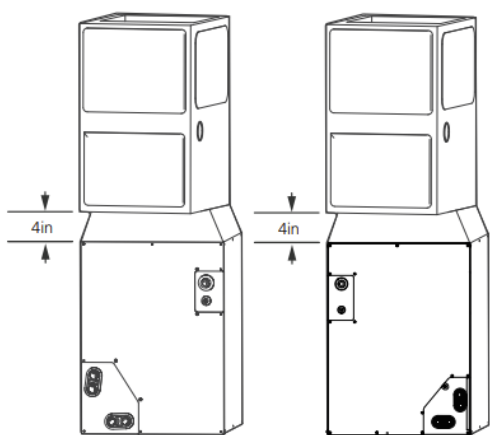

1. Set the cased coil on the supply duct opening.
2. Place a field fabricated 4-in. minimum adapter on the coil casing. The adapter should be tapered to fit the coil/furnace combination when one of them is larger than the other.

3. Set the furnace on the adapter.

NOTE: In a downflow installation with a 4-way multiplies furnace, break off the perforated duct flanges on the furnace. See furnace installation instructions.

### Horizontal Coil Installation:

The unit can be installed on a work platform, secured to roof trusses in the attic, suspended from hangers on floor joist in a crawl space, or installed on blocks. It is designed to allow airflow in either direction, to mate with a horizontal-left or horizontal-right furnace. Ensure the coil cabinet is level side to side and front to back. It is allowable to add up to 1/2-in additional slope over length and depth of the coil cabinet in the direction of the drain pan.

### Horizontal Right Installation:

1. Use a field fabricated attachment plate to secure the coil to the furnace.
2. Use self-tapping screws to mount the attachment plates to the coil casing.

3. Connect the furnace snugly against the coil casing.
4. Seal the joint between the coil casing and the furnace to create an air tight seal using locally approved materials.
5. If the coil is wider than the furnace, use a 4-in minimum transition and self-tapping screws to attach the furnace.

### Horizontal Left Installation:

1. Unbend the 4 tabs at the right side of the casing.
2. Connect the furnace snugly against the coil casing.
3. Use the self-tapping screws to attach the furnace.
4. Seal the joints between the coil casing and the furnace to create an air tight seal using locally approved materials.
5. If the coil is wider than the furnace, use a 4-in minimum transition and self-tapping screws to attach the furnace.

### Condensate Drain Line Connection

## CAUTION

Failure to follow this caution may result in property damage. When installing over a finished ceiling and/or living area, install a field-fabricated secondary condensate pan under the entire unit.

The coil is designed to dispose of accumulated water through built-in condensate drain fittings. It is recommended that PVC fittings be used on the condensate pan. Do not over-tighten, finger tighten plus 1-1/2 turns. Be sure to install plastic plugs in the unused condensate drain fittings. Two 3/4in female threaded pipe connections are provided in each coil condensate pan. A trap is not necessary on the condensate line if on the supply air side of the furnace. Consult local codes for additional restrictions or precautions. If the local codes require a trap, then the following guidelines are suggested to assure proper drainage. Install a trap in the condensate line of the coil as close to the coil as possible. Make the trap at least 3in (76mm) deep and no higher than the bottom of the units condensate drain opening. Pitch the condensate line 1in (25.4mm) for every 10ft. of length to an open drain, sump, exterior drainage. Make sure that the outlet of each trap is below its connection to the condensate pan to prevent condensate from overflowing the drain pan. Prime all traps, test for leaks, and insulate the traps and lines if located above a living area.

# 3 INSTALLATION

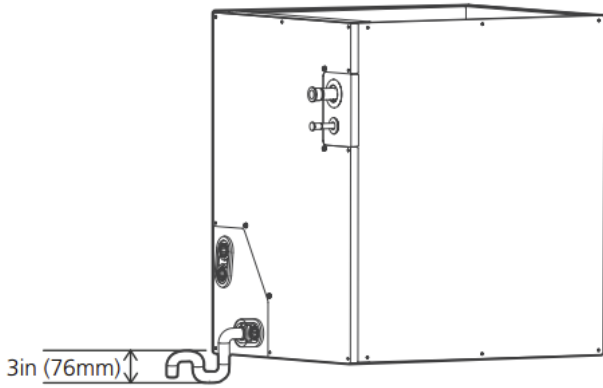

**NOTE:** If the unit is located in or above a living space where damage may result from condensate overflow, a field-supplied, external condensate pan should be installed underneath the entire unit, and a secondary condensate line (with an appropriate trap) should be ran from the unit into the pan. Any condensate in this external condensate pan should be drained to a noticeable place. As an alternative to using an external condensate pan, some localities may allow the running of a separate 3/4in (19mm) condensate line (with an appropriate trap) per local code to a place where the condensate will be noticeable. The owner of the structure must be informed that when condensate flows from a secondary drain or external condensate pan, the unit requires servicing or water damage will occur. To further protect against water damage, install a float switch to shut the unit off if the water in the secondary pan gets to high.

## Air Duct Installation:

Step 1 :Use a tool to fold up the flange  
Clamp it in the middle of the hole and bend it up 90 degrees

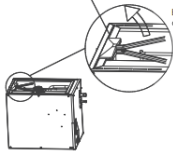

Step 2: Fold the flanges around

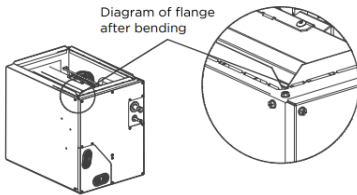

Step 3: Seal all sides with tape and keep warm with sponge.

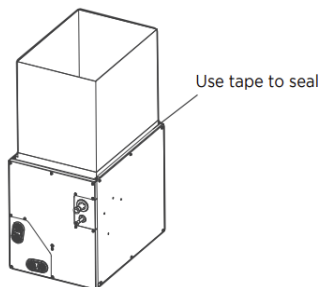

## 3.3 Installation of MINI Interface

1. Choose your install location.  
Priority should be given to installing on the front of the coil, or you can choose to install it on the side or on a nearby wall as needed.

2. Dismantling panels.

Figure 1: installed on the side of the coil (vertical mounting, you can choose left or right).

Figure 2: Installed on the wall of the coil (horizontal mounting).

Figure 3: Installed on the wall of the coil.

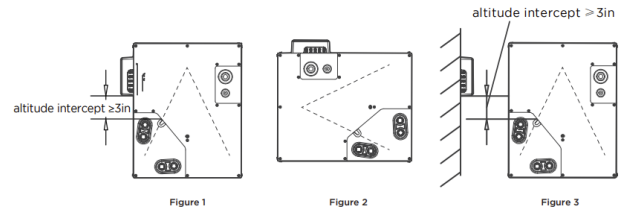

3. Dismantling the control box.

Using a screwdriver, pull at the two positions shown in the diagram.

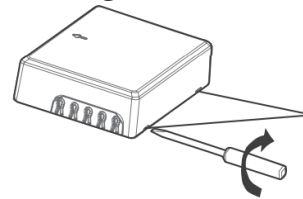

Using a flat-head screwdriver, insert the two marked positions and gently rotate the screwdriver to open the cover.

4. Fixed box.

Fix 3 screws, 2 of which require drilling.

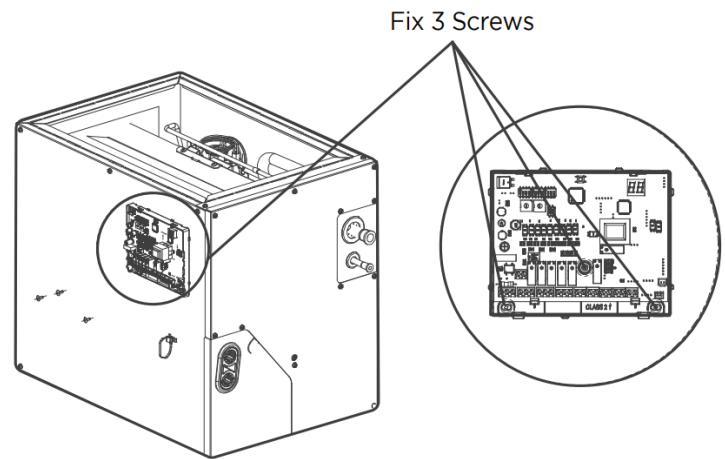

5. Cut off the cover wiring port.



Use pliers to cut the upper cover, and cut the left position according to the diagram.



Close the cover photo

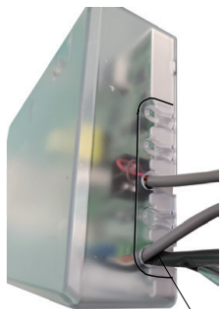

Cut off the appropriate part according to the position for wires outlet. If it is a single wire, you can cut a single wire hole, if there are multiple wires, you can cut off the cover along the maximum outline.

6. Close the lid.  
Close the cover to complete the installation of the control box.

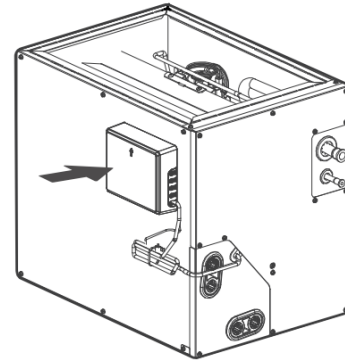

### 3.4 Refrigerant Pipe Installation

**Recommended Copper Pipe Thickness:**

Pipe Diameter (inch(mm))	Thickness (inch/mm)
Ø3/8 (Ø9.52)	0.028/0.7
Ø5/8 (Ø15.9)	0.03/0.75
Ø3/4 (Ø19)	0.031/0.8

**Maximum Length and Drop Height:**

Ensure that the length of the refrigerant pipe, the number of bends, and the drop height between the indoor and outdoor units meets the requirements shown in the following table.

Capacity (kBtu/h)	Max. Length (ft/m)	Max. Elevation (ft/m)
18	98.4/30	65.6/20
24~30	164/50	82/25
36~60	246/75	98.4/30

**Caution:**

- The capacity test is based on the standard length and the maximum permissible length is based on the system reliability.
- Oil traps
  - If oil flows back into the outdoor unit's compressor, this might cause liquid compression or deterioration of oil return. Oil traps in the rising gas piping can prevent this.
  - An oil trap should be installed every 20ft (6m) of vertical suction line riser (<36000Btu/h unit).
  - An oil trap should be installed every 32.8ft (10m) of vertical suction line riser (≥36000Btu/h unit).

# 3 INSTALLATION

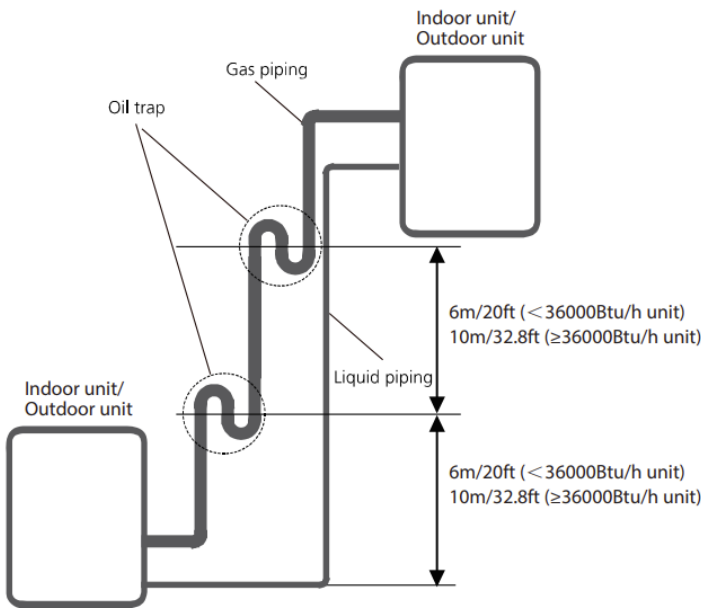

## The Procedure of Connecting Pipes:

1. Choose the pipe size according to the specification table.
2. Confirm the cross way of the pipes.
3. Measure the necessary pipe length.
4. Cut the selected pipe with a pipe cutter.
  - Make the section flat and smooth.

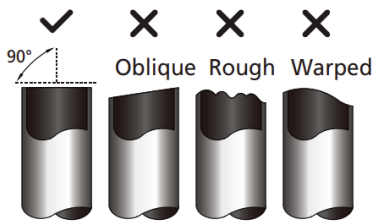

5. Insulate the copper pipe.
  - Before test operation, the joint parts should not be heat insulated.
6. Flare the pipe.
  - Inset a flare nut into the pipe before flaring the pipe
  - According to the following table to flare the pipe.

Pipe Diameter (inch(mm))	Flare Dimension A		Flare Shape
	Min.	Max.	
Ø3/8 (Ø9.52)	0.52/13.2	0.53/13.5	
Ø5/8 (Ø15.9)	0.76/19.2	0.78/19.7	
Ø3/4 (Ø19)	0.91/23.2	0.93/23.7	

- After flaring the pipe, the opening part must be sealed by the end cover or adhesive tape to avoid duct or exogenous impurity's will enter the pipe.
7. Drill holes if the pipes need to pass the wall.
  8. According to the field condition to bend the pipes so that it can pass the wall smoothly.

9. Bind and wrap the wire together with the insulated pipe if necessary.
10. Set the wall conduit.
11. Set the supporter for the pipe.
12. Locate the pipe and fix it by the supporter.
  - For horizontal refrigerant pipe, the distance between supporters should not exceed 3.28ft (1m).
  - For vertical refrigerant pipe, the distance between supporters should not exceed 4.9ft (1.5m).
13. Connect the pie to the indoor and outdoor unit by using two crescent wrenches.
  - Be sure to use two crescent wrenches and proper torque to fasten the nut, too much torque will damage the bellmouthing, and too little may cause a leak. Refer to the following table for different pipe connections.

Pipe Diameter (inch(mm))	Torque	Sketch Map
	N.m (lb.ft)	
Ø3/8 (Ø9.52)	32~39 (23.6~28.8)	
Ø5/8 (Ø15.9)	57~71 (42~52.4)	
Ø3/4 (Ø19)	67~101 (49.4~74.5)	

### NOTE: MINIMUM BEND RADIUS

Carefully bend the tubing in the middle according to the diagram below.  
DO NOT bend the tubing more than 90° or more than 3 times.

Use appropriate tool

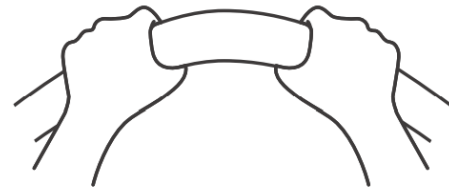

min-radius 10cm(3.9")

## 3.5 Insulation

### Insulation of Refrigerant Pipe:

Cut the pipe—insulation (except joint section)—flare the pipe—piping layout and connection—vacuum—insulate the joining parts

### Purpose of Refrigerant Pipe Insulation:

- During operation the temperature of the gas pipe and liquid pipe will be hot/cold. Therefore, it is necessary to install insulation; otherwise it will lower performance or burn up the compressor.
- The gas pipe temperature is low during cooling. If there is insufficient insulation it will condensate and drip.
- The temperature of the gas pipe is high (122°F~212°F(50°C~100°C) during heating. Insulation must be installed to prevent burns.

## Insulation Material Selection for Refrigerant Pipe:

- The insulation rating should be over 248°F (120°C).
- Choose insulation according to local codes and ordinances.
- The thickness of the insulation should be above 0.39in(10mm). If in a hot or wet environment use thicker insulation.

Humidity<80%RH	Humidity≥80%RH
10mm/0.39in	15mm/0.59in

## Installation Highlights:

- The gas and liquid pipe should be insulated separately, if the gas pipe and liquid pipe were insulated together it will decrease the performance of the system.

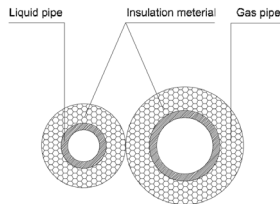

- The insulation material at the joint pipe should be 1.97in~3.97in(5cm~10cm) longer than the gap of insulation material.
- The insulation material at the joint pipe should be inserted into the gap of the insulation material.
- The insulation material at the joint pipe should be banded to the gap pipe and liquid pipe tightly.
- The a joining part should be glued together.
- Be sure not to bind the insulating material over-tight, it may extrude out the air in the material and cause it to rot.

## Insulation of Drainage Pipe:

### Operational procedure of refrigerant pipe insulation.

Select the suitable pipe—insulation (except joint section)—Piping layout and connection—drainage test—insulate the joint parts.

### Purpose of drainage pipe insulation.

The temperature of the condensate drainage water is very low. If the insulation is not enough, it shall for dew and may leak which will cause damage to the house.

### Insulation material selection for drainage pipe.

- The insulation material should be flame retardant material, the flame retardancy of the material should be selected according to the local law.
- Thickness of the insulation layer is usually above 10mm/0.39in.
- Use specific glue to past the seam of insulation material, and then bind with adhesive tape. The width of tape shall not be less than 5cm/1.97in. Make sure it is firm and avoid dew.

### Installation and highlights of insulation construction.

- The single pipe should be insulated before connecting to another pipe, the joint part should be insulated after the drainage test.
- There should be no insulation gap between the insulation material.

## 3.6 Electrical Wiring

### Highlights of Electrical Wiring Installation:

- All wiring must comply with local and national electrical codes, regulations, and must be installed by a licensed electrician.
- All electrical connections must be made according to the Electrical Connection Diagram located on the panels of the indoor and outdoor unit.
- If there is a serious safety issue with the power supply, stop work immediately. Explain your reasoning to the client, and refuse to install the unit until the safety issue is properly resolved.
- Power voltage should be within 90~110% of the rated voltage. Insufficient power supply can cause malfunction, electrical shock, or fire.
- Installation of an external surge suppressor at the outdoor disconnect is recommended.
- If connecting power to fixed wiring, a switch or circuit breaker that disconnects all poles and has a contact separation of at least 1/8in(3mm) must be incorporated in the fixed wiring. The qualified technician must use an approved circuit breaker or switch.
- Only connect the unit to an individual branch circuit. Do not connect another appliance to that outlet.
- Make sure to properly ground the air conditioner.
- Every wire must be firmly connected. Loose wiring can cause the terminal to overheat, resulting in product malfunction and possible fire.
- Do not let wires touch or rest against refrigerant tubing, the compressor, or any moving parts within the unit.
- If the unit has an auxiliary electric heater, it must be installed at least 40in(1m) away from any combustible material.
- To avoid electrical shock, never touch the electrical components after the power supply has been turned off. After turning off the power, always wait 10 minutes or more before you touch the electrical components.
- Make sure that you do not cross your electrical wiring with your signal wiring as this may cause distortion, interference, or possibly damage to the circuit boards.
- No other equipment should be connected to the same power circuit.
- Connect the outdoor wires before connecting the indoor wires.

# 3 INSTALLATION



## WARNING

Before performing any electrical or wiring work, turn off the main power to the system.

### Indoor Wiring:

The power to the unit must be disconnected before any wiring. Be sure to show application of a ferrite clamp and room temp sensor and cable. Make a note to review the different application (scenarios) options for proper wiring. Make sure a strain relief and proper conduit are used when connecting to the box, recommended use of metal-clad cable.

NOTE: Use copper wire only. Separate the power supply leads and communication leads by the strain relief or segregate the power supply leads from the communication leads.

Instruction for installation of the critical-to-safety wiring connection of the leak detection sensor or leak detection system to the furnace assembly. The wiring shall not be less than 18 AWG with a minimum insulation thickness of 1.58mm (1.58mm) or protected from damage. Critical-to safety wiring is any field installed wiring necessary to fulfill the requirements of the minimum room area in the event of a detection of a leak.

The appliance shall not be installed on furnaces with an inductive electrical greater than  $L_e$  as calculated as follows:

The switched electrical load ( $L_e$ ) in kVA is less than or equal to:

- $L_e = 5 * (6,7 / S_u)^4$  when breaking all phases;

- $L_e = 2,5 * (6,7 / S_u)^4$  when breaking two legs of a three-phase load, or when breaking one or two legs of a single phase load.

Where  $L_e$  is the switched inductive electrical load in kilo volt-amperes (kVA);

$S_u$  is the burning velocity of a refrigerant in centimeters per second (cm/s).

Detection of a leak shall turn on the indoor fan at the highest available speed or turn it on to no less than the minimum airflow ( $Q_{hmin}$ ).

Line Gauge		
Outdoor-Indoor Signal Wire	Line Diameter (AWG)	20
24V Signal Wire	Line Diameter (AWG)	18

Signal Wire

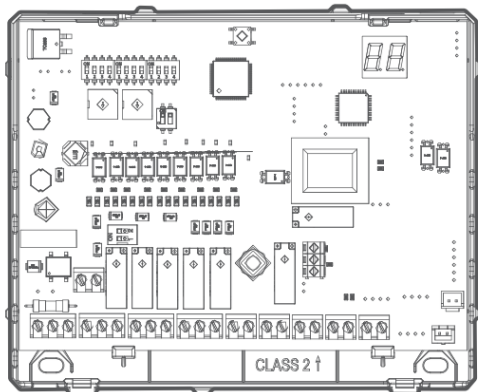

## 4.1 Wiring

### Ratings:

Electrical-Inputs:

Input Type	Input Rating	Terminals	Recommended Wire Range/Torque
Power Input	24VAC, 60Hz, 300mA, Class 2	Terminal Block CN1-3(R), CN1-2(C)	14-22 AWG/0.5N·m
Remove Control Signal Input	12VDC, SELV	CN2	14-22 AWG/0.5N·m

### Communication:

Type	Rating	Terminal	Recommended Wire Range/Torque
Communication Between Indoor and Outdoor Unit	5VDC, Class 2, Limited Energy ( $\leq 15W$ )	CN17	14-22 AWG/0.5N·m
Communication Between Data Conversion Board and External Thermostat	24VAC, 60Hz, Class 2	CN4, CN6, CN11	
Communication Between Data Conversion Module PWB and Centralized Controller	5VDC, Class 2	CN3	
External Communication	18VDC, Class 2, Limited Energy (15W)	CN19	
Communication Between Data Conversion Module PWB and Refrigerant Sensor	5 VDC, Class 2	CN5, CN8	

### Outputs:

Type	Rating	Terminal	Recommended Wire Range/Torque
Control Device for Furnace (Relay, RY7, RY8)	24VAC, 60Hz, Class 2, General Use (Signal Use)	CN9	14-22 AWG/0.5N·m
Control Device for Furnace (Relay, RY9, RY10)	24VAC, 60Hz, Class 2, General Use (Signal Use)	CN10	
Control Device for Outdoor Unit When Full 24V communication (Relay, RY11)		CN43	

# 4 PRODUCT FEATURES

## ! WARNING

Please refer to the wiring nameplate for the wiring method. **DO NOT** connect the power cord to the communication line as this may damage the system.

### Wiring Methods:

NOTE: For method A & B the equipment must have S1 & S2 communication between the indoor and outdoor units.

#### Connection Method A:

Full communication:

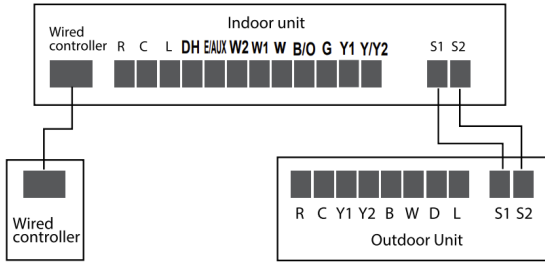

#### Connection Method B:

To use a 24V thermostat, you need to refer to the following wiring:

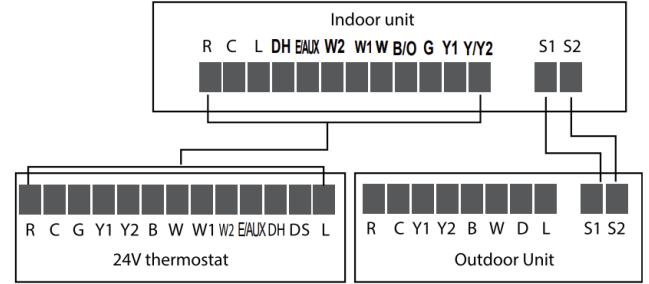

#### Connection method C:

The following wiring diagrams are suitable for the IDU and ODU with 24V thermostat.

#### Non-Communicating scheme wiring reference

NOTE: CN43 terminals OC of A-COIL Mini Interface must be connected to the outdoor unit when the full 24V communication scheme is applied. That will stop the operation of the outdoor unit for safety if there is a refrigerant leak.

#### Wiring for 4H and 2C thermostat

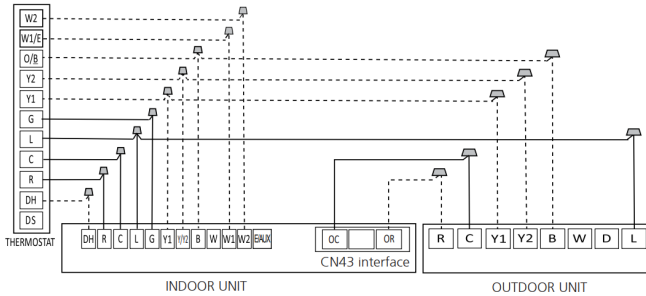

S4-2 Default on, DH function off. Turn switch off to activate DH function.

S4-1 Default on, W1 and W2 shorted for single stage Aux heat operation. Turn off to separate stages.

#### Wiring for 3H and 2C thermostat

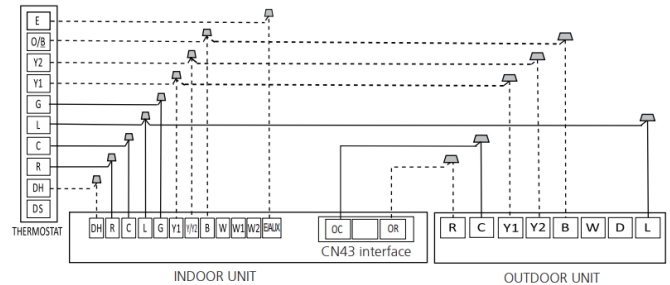

S4-2 Default on, DH function off. Turn switch off to activate DH function.

#### Wiring for 3H and 1C thermostat

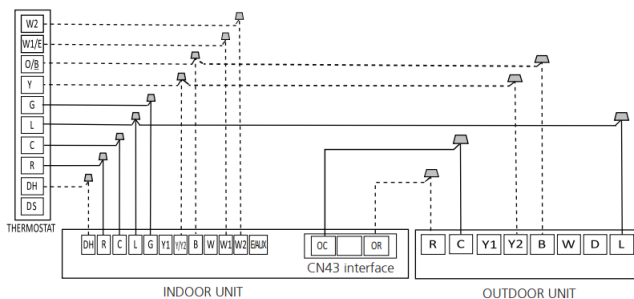

S4-2 Default on, DH function off. Turn switch off to activate DH function.

S4-1 Default on, W1 and W2 shorted for single stage Aux heat operation. Turn off to separate stages.

#### Wiring for 3H and 3C thermostat

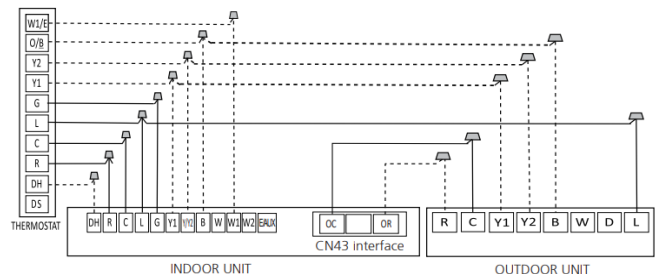

S4-2 Default on, DH function off. Turn switch off to activate DH function.

S4-1 Default on, W1 and W2 shorted for single stage Aux heat operation. Turn off to separate stages.

Wiring for 2H and 2C thermostat

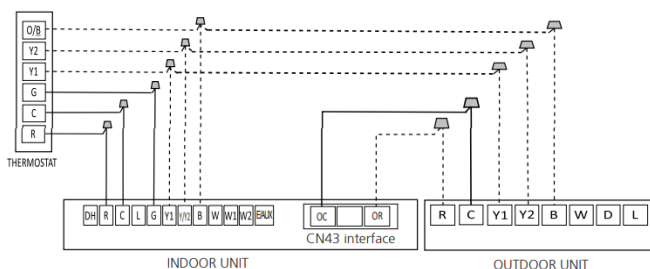

Wiring for 1H and 1C thermostat

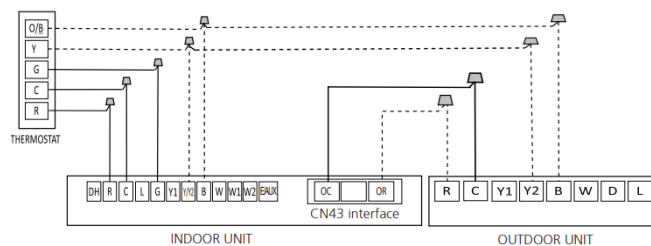

Wiring for 2H and 1C thermostat

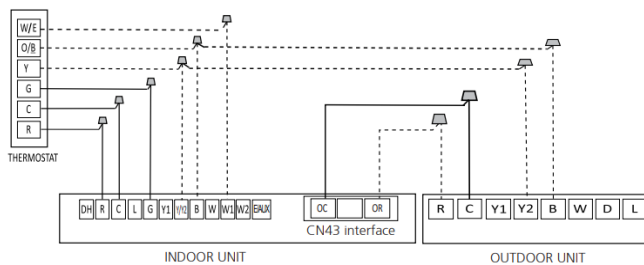

S4-1 Default on, W1 and W2 shorted for single stage Aux heat operation. Turn off to separate stages.

## 4.2 Controls

Control signals to the furnace are the standard thermostat control signals R,C,OW1,OW2,OG,OY1, and OY2.

Connector	Usage
R	Provides 24VAC power from the furnace to the board.
C	The 24VAC common wire between the furnace and the board.
OW1	First stage of furnace command line from the board to the furnace. If the furnaces that only have a W and do not have a S2, connect OW1 to the W of the furnace and make no connection with the OW2 signal wire.
OW2	Second stage of furnace command line from the board to the furnace. OW2 cannot be ON unless OW1 is already ON.
OY1/OG	For 1-speed configuration, connect the OG signal to G of the furnace. For 2-speed configuration, connect the OG signal to G of the furnace and connect the OY1 signal to Y1 of the furnace.
OY2	For 1-speed configuration, connect this signal to Y of the furnace. In this configuration, the OY2 signal turns on when the fan is requested while in Cool or Heat mode using the heat pump. For 2-speed configuration, connect this signal to Y2 of the furnace. In this configuration, the OY2 signal turns on as follows: In Fan, Cool, or Heat mode with the HP when high speed fan is requested. In Auto Fan and Cool mode, the signal goes to high speed when the difference between room temperature and set point temperature is more than or equal to 1.5°C. The signal goes back to low speed when the temperature difference is less than 1°C.

In addition:

Room temperature sensor to be installed in the return air.

Duct temperature sensor to be installed on the COIL as specified.

# 4 PRODUCT FEATURES

## 24V Signal Chart (Cooling & Heating)

Mode	Priority	G	Y1	Y/Y2	B	W	W1	W2	E/AUX	DH	Display
OFF	/	0	0	0	0	0	0	0	0	*	00
FAN	7	1	0	0	*	0	0	0	0	*	01
Cooling Stage 1	6	*	1	0	0	0	0	0	0	1	02
Cooling Stage 2		*	*	1	0	0	0	0	0	1	03
Dehumidification 1		*	1	0	0	0	0	0	0	0	04
Dehumidification 2		*	*	1	0	0	0	0	0	0	05
Heat Pump Stage 1	5	*	1	0	1	0	0	0	0	1	06
Heat Pump Stage 2		*	*	1	1	0	0	0	0	1	
Heat Pump Stage 2		*	*	*	*	1	0	0	0	1	
Furnace	3	*	0	0	*	0	1	0	0	*	12
Furnace		*	0	0	*	0	0	1	0	*	
Furnace		*	0	0	*	0	1	1	0	*	
Furnace	4	*	1	0	1	0	1	0	0	1	12
Furnace		*	1	0	1	0	0	1	0	1	
Furnace		*	*	1	1	0	1	0	0	1	
Furnace		*	*	*	*	1	1	0	0	1	
Furnace		*	*	1	1	0	0	1	0	1	
Furnace		*	*	*	*	1	0	1	0	1	
Furnace		*	1	0	1	0	1	1	0	1	
Furnace	1	*	*	1	1	0	1	1	0	1	12
Furnace		*	*	*	*	1	1	1	0	1	
Furnace		*	*	*	*	1	1	1	0	1	
Furnace	1	*	*	*	*	*	*	*	1	*	12
Heating Zone Control	2	*	1	0	1	0	*	*	0	0	13
Heating Zone Control		*	*	1	1	0	*	*	0	0	
Heating Zone Control		*	*	*	*	1	*	*	0	0	

**Note:**

1: 24V signal  
 0: No 24V signal  
 \*: 1 or 0  
 The AHU will turn off if the 24V input cannot meet the table.

## 4.3 Safety Features (NON-24V control)

### Sensor Redundancy and Automatic Shutoff:

If one temperature sensor malfunctions, the air conditioner continues operation and displays the corresponding error code, allowing for emergency use.

- When more than one temperature sensor is malfunctioning, the air conditioner ceases operation.

### Basic Functions (NON-24V control)

#### Unit Element Abbreviations

Abbreviation	Element
T1	Indoor room temperature sensor
T2	Evaporator coil temperature sensor
T3	Condenser coil temperature sensor
T4	Outdoor ambient temperature sensor
TP	Compressor discharge temperature sensor
TS	Setting Temperature
Tsc	Adjusted setting temperature

### Fan Mode:

#### When fan mode is activated

- Temperature control is disabled and no temperature setting is displayed.
- Auto Fan: In fan-only mode, the system operates the same as auto fan in cooling mode with the temperature set at 75°F (24°C).

### Cooling Mode:

#### Indoor Fan Control

1. In cooling mode, the indoor fan operates continuously. The fan speed can be set to low, medium, high, turbo, and auto:
2. Auto fan action in cooling mode:
  - **Descent Curve**
    - When T1-Tsc is lower than 6°F/3.5°C, the fan speed reduces to high (OY1+OY2).
    - When T1-Tsc is lower than 1°F/2°C, the fan speed reduces to medium (OY1).
    - When T1-Tsc is lower than 0.5°F/1°C, the fan speed reduces to low (OY1).
  - **Rise Curve**
    - When T1-Tsc is higher than or equal to 1°F/2°C, the fan speed increases to medium (OY1).
    - When T1-Tsc is higher than or equal to 3°F/1.5°C, the fan speed increases to high (OY1+OY2).
    - When T1-Tsc is higher than or equal to 7°F/4°C, the fan speed increases to turbo (OY1+OY2).

### Evaporator Temperature Protection:

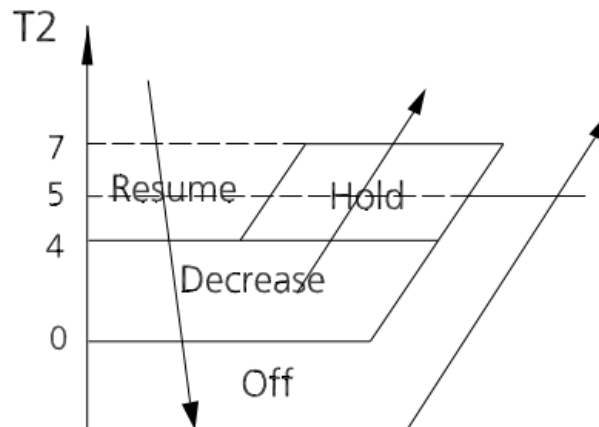

- Off: Compressor Stops.
- Decrease: Decreases the running frequency to the lower level per 1 minute.
- Hold: Keep the current frequency.
- Resume: No limitation for frequency.

### HEATING MODE:

#### Indoor Fan Control

1. In heating mode, the indoor fan operates continuously. The fan speed can be set to low, medium, high, turbo, and auto.
  - Anti-cold air function.
    - Set machine: G1 G2 does not output within 1 minute of compressor stop or compressor turn on in single heat pump mode, and output the set fan after 1 minute of compressor opening.
    - Set machine: After exiting defrost, the fan is delayed for 30s before output.
    - Single indoor machine: no anti-cold air function, according to the set fan output. (When the indoor unit is faulty, the set fan output will still be sent according to the display).
2. Auto fan action in heating mode:
  - **Rise Curve**
    - When T1-Tsc is lower than -3°F/-1.5°C, the fan speed reduces to high (OY1+OY2).
    - When T1-Tsc is lower than 0°F/0°C, the fan speed reduces to medium (OY1).
    - When T1-Tsc is lower than 1°F/0.5°C, the fan speed reduces to low (OY1).
  - **Descent Curve**
    - When T1-Tsc is higher than or equal to 0°F/0°C, the fan speed increases to medium.
    - When T1-Tsc is higher than or equal to -3°F/-1.5°C, the fan speed increases to high (OY1+OY2).
    - When T1-Tsc is higher than or equal to -5°F/-3°C, the fan speed increases to turbo (OY1+OY2).

# 4 PRODUCT FEATURES

## Evaporator Coil Temperature Protection:

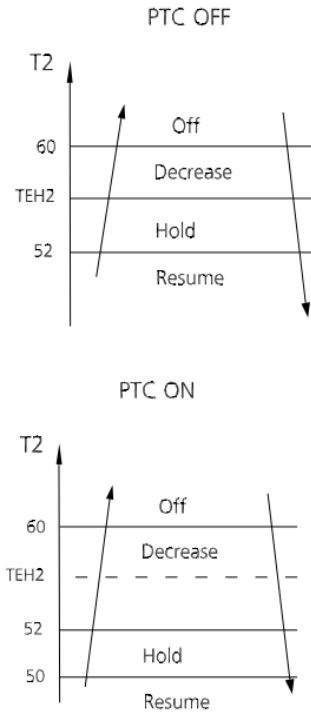

- Off: Compressor stops.
- Decrease: Decrease the running frequency to the lower level per 20 seconds.
- Hold: Keep the current frequency.
- Resume: No limitation for frequency.

## Auto-Mode:

- This mode can be selected with the remote controller and the temperature setting can be adjusted between 61°F~86°F (16°C~30°C).
- In auto mode, the machine selects cooling, heating, or fan-only mode on the basis of  $\Delta T$  ( $\Delta T = T1 - Ts$ ).

$\Delta T$	Running Mode
$\Delta T > 3.6^\circ\text{F} (2^\circ\text{C})$	Cooling
$-5.4^\circ\text{F} (-3^\circ\text{C}) \leq \Delta T \leq 3.6^\circ\text{F} (2^\circ\text{C})$	Fan-Only
$\Delta T < -5.4^\circ\text{F} (-3^\circ\text{C})$	Heating*

Heating\*: In auto mode, cooling only models run the fan

- Indoor fan will run at auto fan speed.
- If the machine switches mode between heating and cooling, the compressor will keep stopping for a certain time and then choose the mode according to the  $\Delta T$ .

## Drying Mode:

### Indoor Fan Control

1. In drying mode, the indoor fan operates continuously. The fan speed can be set to low, medium, high, turbo, and auto.

2. Auto fan action in drying mode:

- **Descent curve**
  - When  $T1 - Tsc$  is lower than  $6^\circ\text{F}/3.5^\circ\text{C}$ , the fan speed reduces to high (OY1+OY2).
  - When  $T1 - Tsc$  is lower than  $2^\circ\text{F}/1^\circ\text{C}$ , the fan speed reduces to medium (OY1).
  - When  $T1 - Tsc$  is lower than  $1^\circ\text{F}/0.5^\circ\text{C}$ , the fan speed reduces to low (OG).
- **Rise Curve**
  - When  $T1 - Tsc$  is higher than or equal to  $2^\circ\text{F}/1^\circ\text{C}$ , the fan speed increases to medium (OY1).
  - When  $T1 - Tsc$  is higher than or equal to  $3^\circ\text{F}/1.5^\circ\text{C}$ , the fan speed increases to high (OY1+OY2).
  - When  $T1 - Tsc$  is higher than or equal to  $7^\circ\text{F}/4^\circ\text{C}$ , the fan speed increases to turbo (OY1+OY2).
- **All protections are activated and operate the same as they do in cooling mode.**

### Low temperature protection

If the room temperature is lower than  $50^\circ\text{F}/10^\circ\text{C}$ , the compressor ceases operations and does not resume until the room temperature exceeds  $54^\circ\text{F}/12^\circ\text{C}$ .

### Forced Operation Function:

Press the AUTO/COOL button, the system will run as the sequence below:

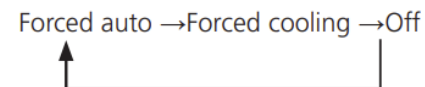

- **Forced cooling mode:**

The compressor and outdoor fan continue to run and the indoor fan runs at breeze speed. After running for 30 minutes, the system will switch to auto mode with a preset temperature of  $76^\circ\text{F}/24^\circ\text{C}$ .

- **Forced auto mode:**

Forced auto mode operates the same as normal auto mode with a preset temperature of  $76^\circ\text{F}/24^\circ\text{C}$ .

- The unit exits forced operation when it receives the following signals:

Receives the remote signal to change the running mode:

### Timer Function:

- The timing range is 24 hours.
- **Timer On.** The machine turns on automatically at the preset time.
- **Timer Off.** The machine turns off automatically at the preset time.
- **Timer On/Off.** The machine turns on automatically at the preset On Time, and then turns off automatically at the preset Off Time.
- **Timer Off/On.** The machine turns off automatically at the preset Off Time and then turns on automatically at the preset On Time.
- The timer does not change the units operation mode. If the unit is off now, it does not start up immediately after the "timer off" function is set. When the setting time is reached, the timer LED switches off and the unit running mode remains

unchanged.

- The timer uses relative time, not clock time.

## **Sleep Function:**

- The sleep function is available in cooling, heating, auto mode, or Heat Pump + Electric Heater.
- The operational process for sleep mode is as follows:
  - When cooling, the temperature rises 2°F/1°C (to no higher than 86°F/30°C) every hour. After 2 hours, the temperature stops rising and the indoor fan is fixed at a low speed.
  - When heating, the temperature decreases 2°F/1°C (to no lower than 61°F/16°C) every hour. After 2 hours, the temperature stops decreasing and the indoor fan is fixed at a low speed. Anti-cold wind function takes priority.
- When in auto mode, the fan speed is also fixed at a low speed. After 1 hour, if the actual operation mode is cooling mode, the set temperature will rise by 2°F/1°C, if it is in heating mode, the set temperature will decrease by 2°F/1°C, if it is in fan mode, the set temperature will not change, and the set temperature will not change after two hours of operation.
- The timer setting is available in this mode.

## **Auto-Restart Function:**

- The indoor unit has an auto-restart module that allows the unit to restart automatically. The module automatically stores the current settings and in the case of a sudden power failure, will restore those settings automatically within 3 minutes after power returns.

# 5 TROUBLESHOOTING

## 5.1 Safety Caution

### WARNING

Be sure to turn off all power supplies or disconnect all wires to avoid electric shock. While checking the indoor/outdoor PCB, please equip yourself with anti-static gloves or a wrist strap to avoid damaging the board.

Electricity will remain in capacitors even when the power supply is off. Ensure the capacitors are fully discharged before troubleshooting

## 5.2 Error Display (Indoor Unit)

Display	Error Information	Solution
EC 07	ODU fan speed out of control	TS21
EC 0d	ODU malfunction	TS38
EC 51	ODU EEPROM parameter error	TS19
EC 52	ODU coil temp. sensor (T3) error	TS23
EC 53	ODU ambient temp. sensor (T4) error	TS23
EC 54	COMP. discharge temp. sensor (TP) error	TS23
EC 56	IDU coil outlet temp. sensor (T2B) error (multi-zone)	TS23
EC C1	Other IDU refrigerant sensor detects leakage (multi-zone)	TS35
EH 00	IDU EEPROM Malfunction	TS19
EH 03	IDU fan speed out of control	TS21
EH 0A	IDU EEPROM parameter error	TS19
EH 0B	IDU main control board and display board communication error	TS39
EH 0E	Water-level alarm malfunction	TS25
EH 3A	External fan DC bus voltage is too high fault	TS35
EH 3b	External fan DC bus voltage is too high fault	TS35
EH 60	IDU room temp. sensor (T1) error	TS23
EH 61	IDU evaporator coil temp. sensor (T2) error	TS23
EH bA	Communication error between the indoor unit and external fan module	TS35
EH C1	Refrigerant sensor detects leakage	TS37
EH C2	Refrigerant sensor is out of range and leakage is detected	TS37
EH C3	Refrigerant sensor is out of range	TS36
EL 01	IDU & ODU communication error	TS20
EL 0C	System lacks refrigerant	TS23
EL 16	Communication malfunction between adapter board and outdoor main board	TS40
FH CC	Refrigerant sensor error	TS36
FL 09	Mismatch between the new and old platforms	TS40
PC 00	ODU IPM module protection	TS26
PC 01	ODU voltage protection	TS27
PC 02	Compressor top (or IPM) temp. protection	TS32
PC 03	Pressure protection (low or high pressure) (for some models)	TS29
PC 04	Inverter compressor drive error	TS28
PC 0L	Low ambient temperature protection (for some models)	TS33
----	IDUs mode conflict (Multi-zone)	--

### For Other Errors:

The display board may show a garbled code or a code undefined by the service manual. Ensure that this code is not a temperature reading.

### Troubleshooting:

Test the unit using the remote control. If the unit does not respond to the remote, the indoor PCB requires replacement. If the unit responds, the display board requires replacement.

### LED flash Frequency:

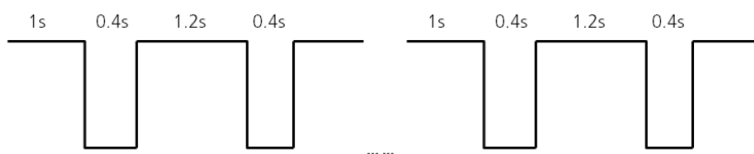

## Error Display on Two Way Communication Wired Controller:

Display	Error Information	Solution
EH b3	Communication malfunction between wire and master control (for KJR-120X/KJR-120M/KJR-120N series wired controller)	TS34

The other error codes displayed on the wire controller are the same from those on the unit.

### 5.3 Information Inquiry & Setting

In order to enter to engineering mode and check the data of the system (data checking mode), please follow these steps:

- Make sure that the system is in standby status or working in non-locked conditions.
- Press the "Power" + "Fan" buttons together for 7s until the remote controller screen shows "0", and also "Auto, Cool, Dry, Heat, Battery" icons will be displayed at the same time.
- Press the "UP" or "Down" buttons to choose different channel numbers that want to check (from 0-30) on the remote controller, and then the display will show the parameter value.

Channel	Code	Meaning	Remark
0		Error Code	Refer to the next list of error codes Empty means no error code
1	T1	Room temperature	Actual data, °C
2	T2	Indoor coil temperature	Actual data, °C
3	T3	Outdoor coil temperature	Actual data, °C
4	T4	Ambient temperature	Actual data, °C
5	TP	Discharge temperature	Actual data, °C
6	FT	Targeted frequency	Actual data
7	Fr	Actual frequency	Actual data
8	dl	Running current	3.2A-3
9	Ac	AC voltage	
10	Sn	Reserved	
11	--	Indoor operating mode	
12	Pr	Outdoor fan speed	1:low, 2:middle, 3:high, 4:turbo (OW1/OW2)
13	Lr	EXV opening steps	Actual data/8
14	lr	Indoor fan speed	1:low, 2:middle, 3:high, 4:turbo (OW1/OW2)
15	Hu	Humidity (if a sensor is there)	Actual data, %
16	TT	Set temperature including compensation	Actual data, °C
17	nA	Reserved	
18	nA	Reserved	
19	Uo	Outdoor DC bus voltage	
20	oT	Target Frequency calculated by indoor	Without limitation
21~30	nA	Reserve	

#### Note:

1. The channel number indicates a certain parameter value (Check next table).
2. The indoor unit display will show the code for 2s and then the parameter value.
3. In the engineering mode, the other keys or operations are invalid except for the following buttons "Power", "Up", "Down", and "Ok".
4. In order to exit from the engineering mode, press the "Power" + "Fan" buttons together for 2s to quit checking and return back to the home screen
5. The engineering mode will be exited if there is no valid input data for 60s.

## Error Code of Engineer Mode:

Display	Error Information
EH 00	IDU EEPROM malfunction
EH 0A	Indoor EEPROM parameter error
EL 01	IDU & ODU communication error
EH bA	Communication error between indoor unit and indoor external fan module
EH 30	Parameters error of indoor external fan
EH 35	Phase failure of indoor external fan
EH 36	Indoor external fan current sampling bias fault
EH 37	Indoor external fan zero speed failure
EH 38	Indoor external fan stall failure
EH 39	Out of step failure of indoor external fan
EH 3A	Low voltage protection of indoor external fan DC bus
EH 3b	Indoor external fan DC bus voltage is too high fault
EH 3E	Indoor external fan overcurrent fault
EH 3F	Indoor external fan module protection/hardware overcurrent protection
EH 03	IDU fan speed out of control
EC 51	ODU EEPROM parameter error
EC 52	ODU coil temp. sensor (T3) error
EC 53	ODU ambient temp. sensor (T4) error
EC 54	COMP. Discharge temp. sensor (TP) error
EC 55	ODU IPM module temp. sensor (TH) error
EC 0d	Outdoor unit malfunction
EH 60	IDU room temp. sensor (T1) error
EH 61	Evaporator coil temperature sensor T2 is in open circuit or short circuit
EC 71	Outdoor external fan overcurrent fault
EC 75	Outdoor external fan module protection/hardware overcurrent protection
EC 72	Outdoor external fan phase failure
EC 74	Outdoor external fan current sampling bias fault
EC 73	Zero speed failure of outdoor unit DC fan
EC 07	ODU fan speed out of control
EH b5	Intelligent eye communication failure
EL 0C	System lacks refrigerant
EH 0E	Water-level alarm malfunction
EH 0F	Intelligent eye malfunction
FH 07	Communication malfunction between indoor unit and auto-lifting panel
PC 00	ODU IPM module protection
PC 10	Over low voltage protection
PC 11	Over voltage protection
PC 12	DC voltage protection

# 5 TROUBLESHOOTING

Display	Error Information
PC 02	Top temperature protection of compressor High temperature protection of IPM module
PC 40	Communication error between outdoor main chip and compressor driven chip
PC 41	Current Input detection protection
PC 42	Compressor start error
PC 43	Lack of phase (3 phase) protection
PC 44	Outdoor unit zero speed protection
PC 45	341PWM error
PC 46	Compressor speed malfunction
PC 49	Compressor over current protection
PC 06	Compressor discharge temperature protection
PC 08	Outdoor current protection
PH 09	Anti-cold air in heating mode
PC 0f	PFC module malfunction
PC 30	System overpressure protection
PC 31	System pressure is too low protection
PC 03	Pressure protection
PC 0L	Outdoor low ambient temperature protection
PH 90	Evaporator coil temperature over high protection
PH 91	Evaporator coil temperature over low protection
PC 0A	Condenser high temperature protection
PH 0C	Indoor unit humidity sensor failure
LH 00	Frequency limit caused by T2
LH 30	Indoor external fan current limit
Lh 31	Indoor external fan voltage limit
LC 01	Frequency limit caused by T3
LC 02	Frequency limit caused by TP
LC 05	Frequency limit caused by voltage
LC 03	Frequency limit caused by current
LC 06	Frequency limit caused by PFC
LC 30	Frequency limit caused by high pressure
LC 31	Frequency limit caused by low pressure
LH 07	Frequency limit caused by remote controller
----	IDUs comm. conflict (match with multi outdoor unit)
NA	No malfunction and protection

## Advanced Function Setting:

In order to enter to the engineering mode and check the advanced function settings please follow these steps.

### If you want to check the current functions set value (Presetting Page):

1. First, you will need to disconnect the power supply from the unit and wait 1 minute.
2. Then re-connect the power supply to the unit and it should enter standby mode.
3. Press the "Power" + "Fan" buttons together for 7s until the remote controller screen shows "0", then the "Auto, Cool, Dry, Heat, Battery" icons will be displayed at the same time.
4. Press "UP" or "Down" buttons to choose different channel numbers that you want to check (from 0-30) on the remote controller.
5. The press the "Power" button for 2s until the remote controller screen shows "Ch".
6. Press the "OK" button to query the current function set value while the remote controller shows "Ch" and the function set vale will be shows on the indoor units display.

### If you want to change the current functions set value:

1. First, you will need to disconnect the power supply form the unit and wait 1 minute.
2. Then connect the power supply again to the unit and it should enter standby mode.
3. Press the "Power" + "Fan" buttons together for 7s until the remote controller screen shows "0" then the "Auto, Cool, Dry, Heat, Battery" icons will be displayed at the same time.
4. Press the "UP" or "Down" buttons to choose different channel numbers that you want to change (from 0~30) on the remote controller.
5. The press the "Power" button for 2s until the remote controller screen shows "Ch".
6. Press the "Up" or "Down" button to choose the desired set value from the screen of the remote control.
7. The press "OK" to send the new set value to the indoor unit, the indoor will display "CS" which means that the new set value is uploaded successfully.
8. Finally, disconnect the power supply again from the unit and wait for 10 minutes then re-connect.

### Note:

1. The channel number indicates a certain function and each number will be showed on the indoor units screen indicates the current function set value (Check the table following table).
2. In the engineering mode the other keys or operations are invalid except for the following buttons "Power", "Up", "Down", and "OK".
3. I order to set a new set value successfully you need to finish the steps (from 2 to 7) within 1 minute only.
4. The engineering mode will be exited if there is no valid input data for 60s.
5. In order to exit from the engineering mode please follow these steps.
  - Press the "Power" button for 2s until the remote controller screen shows "0".
  - The press the "Power" + "Fan" buttons together for 2s to quit the engineering mode and back to the home screen.

# 5 TROUBLESHOOTING

Channel	Function	Parameter Value Meaning	Remark
0	Capacity setting (Btu/h)	1-100K	
1	Auto-restart function	0- Inactive 1- Active	24V control is invalid
2	Fan control when Ts reached	1- Fan stop 2- Fan runs at lowest RPM 3- Fan runs at setting RPM 4- Fan stops for 4 mins and runs for 1 min 5- Fan stops for 8 mins and runs for 1 min 6- Fan stops for 16 mins and runs for 1 min 7- Fan stops for 24 mins and runs for 1 min 8- Fan stops for 48 mins and runs for 1 min 9- Fan stops for 15 mins and runs for 2.5 mins 10- Fan stops for 30 mins and runs for 2.5 mins 11- Fan stops for 60 mins and runs for 2.5 mins 12- Fan runs at setting RPM, but stops if automatic speed is chosen 13- Fan runs at lowest speed, but stops if automatic speed is chosen	24V control is invalid
3	Mode lock	CH- Cooling and heating (all modes) CC- Cooling only (Cooling + Drying + Fan only)	Remote controller will change as well.
4	Lowest setting temperature	16-24	Remote controller will change as well. 24V control is invalid
5	Highest setting temperature	25-30	Remote controller will change as well. 24V control is invalid
6	Reserved	Nothing to set	
7	/	Nothing to set	
8	/	Nothing to set	
9	/	Nothing to set	
10	/	Nothing to set	
11	Min. frequency limitation in cooling mode	10,11,12,..., 49,50,-- (cancel)	Single indoor unit is invalid
12	Min. frequency limitation in heating mode	20,21,22,...,49,50,-- (cancel)	Single indoor unit is invalid
13	/	Nothing to set	
14	/	Nothing to set	
15	Frequency selection of outdoor forced-operation	10,11,12,...,249,250,-- (cancel)	Single indoor unit is invalid
16	One button reset	rS- Reset	
17	nA	Nothing to set	
18	/	Nothing to set	
19	Max. frequency selection in cooling mode	40,41,42,...,83,84,-- (cancel)	Single indoor unit is invalid
20	/	Nothing to set	Without limitation
21	Cooling temperature compensation	-3.0,-2.5,-2.0,...,3.0,3.5,-- (cancel)	24V control is invalid
22	Heating temperature compensation	-6.5,-6.0,-5.5,...,0.5,1.0,1.5,...,7.0,7.5,-- (cancel)	24V control is invalid
23	Reserved	Nothing to set	

Channel	Function	Parameter Value Meaning	Remark
24	Reserved	Nothing to set	
25	Reserved	Nothing to set	
26	Reserved	Nothing to set	
27	Defrosting type	A0- Normal defrosting A1- Enhanced defrosting	Single indoor unit is invalid
28	Reserved	Nothing to set	
29	Reserved	Nothing to set	
30	Reserved	Nothing to set	

## 5.4 Error Diagnosis Without Error Code

### Remote Maintenance:

*Suggestion: When troubles occur, please check the following points with the customer before field maintenance.*

No.	Problem	Solution
1	Unit will not start	TS14-TS15
2	The power switch is on but fans will not start	TS14-TS-15
3	The temperature on the display board cannot be set	TS14-TS-15
4	Unit is on but the air is not cold/hot	TS14-TS-15
5	Unit runs but shortly stops	TS14-TS-15
6	The unit starts up and stops frequently	TS14-TS-15
7	Unit runs continuously but insufficient cooling/heating	TS14-TS-15
8	Cool cannot change to heat	TS14-TS-15
9	Unit is noisy	TS14-TS-15

### Field Maintenance:

No.	Problem	Solution
1	Unit will not start	TS16-TS17
2	Compressor will not start but fans run	TS16-TS17
3	Compressor and condenser fan will not start	TS16-TS17
4	Air handler fan will not start	TS16-TS17
5	Condenser fan will not start	TS16-TS17
6	Unit runs but shortly stops	TS16-TS17
7	Compressor short-cycles due to overload	TS16-TS17
8	High suction pressure	TS16-TS17
9	Low discharge pressure	TS16-TS17
10	High suction pressure	TS16-TS17
11	Low suction pressure	TS16-TS17
12	Unit runs continuously but insufficient cooling	TS16-TS17
13	Too cool	TS16-TS17
14	Compressor is noisy	TS16-TS17
15	Horizontal louver cannot revolve	TS16-TS17

# 5 TROUBLESHOOTING

1. Remote Maintenance	Electrical Circuit								Refrigerant Circuit					
Possible causes of trouble	Power failure	The main power tripped	Loose connections	Faulty transformer	The voltage too high or too low	The remote control is powered off	Broken the remote control	Dirty air filter	Dirty condenser fins	The setting temperature is higher/lower than the room's(cooling/heating)	The ambient temperature is too high/low when the mode is cooling/heating	Fan mode	Silence function is activate	Frosting and defrosting frequency
Unit will not start	√	√	√	√	X	X	X	X	X	X	X	X	X	X
The power switch is on but fans will not start	X	X	√	√	√	X	X	X	X	X	X	X	X	X
The temperature on the playboard cannot be set	X	X	X	X	X	√	√	X	X	X	X	X	X	X
Unit is on but the air is not cold/hot	X	X	X	X	X	X	X	X	X	√	√	√	X	X
Unit runs but shortly stops	X	X	X	X	√	X	X		X	√	√	X	X	X
The unit startup and stops frequently	X	X	X	X	√	X	X	X	X	X	√	X	X	√
Unit runs continuously but insufficient cooling/heating	X	X	X	X	X	X	X	√	√	√	√	X	√	X
Cool cannot change to heat	X	X	X	X	X	X	X	X	X	X	X	X	X	X
Unit is noisy	X	X	X	X	X	X	X	X	X	X	X	X	X	X
Test method/ remedy	Test voltage	Close the power switch	Inspect connections - tighten	Change the transformer	Test voltage	Replace the battery of the remote control	Replace the remote control	Clean or replace	Clean	Adjust the setting temperature	Turn on the unit later	Adjust to cool mode	Turn off the silence function	Turn on the unit later

1. Remote Maintenance	Others					
Possible causes of trouble	Heavy load condition	Loosen hold down bolts or screws	Bad airproof	The air inlet or outlet of either unit is blocked	Interference from cell phone towers and remote boosters	Shipping plates remain attached
Unit will not start	X	X	X	X	X	X
The power switch is on but fans will not start	X	X	X	X	√	X
The temperature on the playboard cannot be set	X	X	X	X	X	X
Unit is on but the air is not cold/hot	X	X	X	X	X	X
Unit runs but shortly stops	X	X	X	X	X	X
The unit startup and stops frequently	X	X	X	√	X	X
Unit runs continuously but insufficient cooling/heating	√	X	√	√	X	X
Cool cannot change to heat	X	X	X	X	X	X
Unit is noisy	X	√	X	X	X	√
Test method/ remedy	Check heat load	Tighten bolts and screws	Close all windows and doors	Remove the obstacles	Reconnect the power or press ON/OFF button on the remote to restart operation	Remove item

# 5 TROUBLESHOOTING

2. Field Maintenance	Refrigerant Circuit																Others						
Possible causes of trouble	Compressor stuck	Shortage of refrigerant	Restricted liquid line	Dirty air filter	Dirty evaporator coil	Insufficient air through evaporator coil	Overcharge of refrigerant	Dirty or partially blocked condenser	Air or incompressible gas in refrigerant cycle	Short cycling of condensing air	High temperature condensing medium	Insufficient condensing medium	Broken compressor internal parts	Inefficient compressor	Expansion valve obstructed	Expansion valve or capillary tube close completely	Leaking power element on expansion valve	Poor installation of feeler bulb	Heavy load condition	Loosen hold down bolts and/or screws	Shipping plates remain attached	Poor choices of capacity	Contact of piping with other piping or external plate
Unit will not start	X	X	X	X	X	X	X	X	X	X	X	X	X	X	X	X	X	X	X	X	X	X	X
Compressor will not start but fans run	√	X	X	X	X	X	X	X	X	X	X	X	X	X	X	X	X	X	X	X	X	X	X
Compressor and condenser fan will not start	X	X	X	X	X	X	X	X	X	X	X	X	X	X	X	X	X	X	X	X	X	X	X
Air handler fan will not start	X	X	X	X	X	X	X	X	X	X	X	X	X	X	X	X	X	X	X	X	X	X	X
Condenser fan will not start	X	X	X	X	X	X	X	X	X	X	X	X	X	X	X	X	X	X	X	X	X	X	X
Unit runs but shortly stops	X	√	√	X	X	X	√	√	X	X	X	X	X	X	√	√	X	X	X	X	X	X	X
Compressor short-cycles due to overload	X	√	X	X	X	X	√	√	X	X	X	X	X	X	X	X	X	X	X	X	X	X	X
High discharge pressure	X	X	X	X	X	X	√	√	√	√	√	√	X	X	X	X	X	X	X	X	X	X	X
Low discharge pressure	X	√	X	X	X	X	X	X	X	X	X	X	√	X	X	X	X	X	X	X	X	X	X
Test method/ remedy	Replace the compressor	Leak test	Replace restricted part	Clean or replace	Clean coil	Check fan	Change charged refrigerant volume	Clean condenser or remove obstacle	Purge, evacuate and recharge	Remove obstruction to air flow	Remove obstruction in air or water flow	Remove obstruction in air or water flow	Replace compressor	Test compressor efficiency	Replace valve	Replace valve	Replace valve	Fix feeler bulb	Check heat load	Tighten bolts or screws	Remove them	Choose system of larger capacity or add another system	Rectify piping so as to not contact with each other or with external plate

2. Field Maintenance	Refrigerant Circuit																	Others					
Possible causes of trouble	Compressor stuck	Shortage of refrigerant	Restricted liquid line	Dirty air filter	Dirty evaporator coil	Insufficient air through evaporator coil	Overcharge of refrigerant	Dirty or partially blocked condenser	Air or incompressible gas in refrigerant cycle	Short cycling of condensing air	High temperature condensing medium	Insufficient condensing medium	Broken compressor internal parts	Inefficient compressor	Expansion valve obstructed	Expansion valve or capillary tube close completely	Leaking power element on expansion valve	Poor installation of feeler bulb	Heavy load condition	Loosen hold down bolts and/or screws	Shipping plates remain attached	Poor choices of capacity	Contact of piping with other piping or external plate
High suction pressure	X	X	X	X	X	X	√	X	X	X	X	X	√	X	X	X	√	√	X	X	X	X	X
Low suction pressure	X	√	√	√	√	√	X	X	X	X	X	X	X	√	√	√	X	X	X	X	X	X	X
Unit runs continuously but insufficient cooling	X	√	√	√	√	√	X	√	√	√	X	X	√	X	X	X	X	√	X	X	√	X	X
Too Cool	X	X	X	X	X	X	X	X	X	X	X	X	X	X	X	X	X	X	X	X	X	X	X
Compressor is noisy	X	X	X	X	X	X	√	X	X	X	X	√	X	X	X	X	X	X	√	√	X	√	√
Horizontal louver cannot revolve	X	X	X	X	X	X	X	X	X	X	X	X	X	X	X	X	X	X	X	X	X	X	X
Test method/ remedy	Replace the compressor	Leak test	Replace restricted part	Clean or replace	Clean coil	Check fan	Change charged refrigerant volume	Clean condenser or remove obstacle	Purge, evacuate and recharge	Remove obstruction to air flow	Remove obstruction in air or water flow	Remove obstruction in air or water flow	Replace compressor	Test compressor efficiency	Replace valve	Replace valve	Replace valve	Fix feeler bulb	Check heat load	Tighten bolts or screws	Remove them	Choose system of larger capacity or add another system	Rectify piping so as to not contact with each other or with external plate

# 5 TROUBLESHOOTING

2. Field Maintenance	Electrical Circuit														
Possible causes of trouble	Power Failure	Blown fuse or varistor	Loose connections	Shorted or broken wires	Safety device opens	Faulty thermostat/room temperature sensor	Wrong setting place of temperature sensor	Faulty transformer	Shorted or open capacitor	Faulty magnetic contactor for compressor	Faulty magnetic contactor for fan	Low voltage	Faulty stepping motor	Shorted or grounded compressor	Shorted or grounded fan motor
Unit will not start	√	√	√	√	√	X	X	√	X	X	X	X	X	X	X
Compressor will not start but fans run	X	X	X	√	X	√	X	√	√	X	X	X	X	√	X
Compressor and condenser fan will not start	X	X	X	√	X	√	X	X	X	√	X	X	X	X	X
Air handler fan will not start	X	X	X	√	X	X	X	X	√	X	√	X	X	X	√
Condenser fan will not start	X	X	X	√	X	√	X	X	√	X	√	X	X	X	√
Unit runs but shortly stops	X	X	X	X	X	X	X	X	X	√	X	√	X	X	X
Compressor short-cycles due to overload	X	X	X	X	X	X	X	X	X	√	X	√	X	X	X
High discharge pressure	X	X	X	X	X	X	X	X	X	X	X	X	X	X	X
Low discharge pressure	X	X	X	X	X	X	X	X	X	X	X	X	X	X	X
Test method/ remedy	Test voltage	Inspect fuse type & size	Inspect connections - tighten	Test circuits with tester	Test continuity of safety device	Test continuity of thermostat/ sensor & wiring	Place the temperature sensor at the central of the air inlet grille	Check control circuit with tester	Check capacitor with tester	Test continuity of coil & contacts	Test continuity of coil & contacts	Test voltage	Replace the stepping motor	Check resistance with multimeter	Check resistance with multimeter

2. Field Maintenance	Electrical Circuit														
Possible causes of trouble	Power Failure	Blown fuse or varistor	Loose connections	Shorted or broken wires	Safety device opens	Faulty thermostat/room temperature sensor	Wrong setting place of temperature sensor	Faulty transformer	Shorted or open capacitor	Faulty magnetic contactor for compressor	Faulty magnetic contactor for fan	Low voltage	Faulty stepping motor	Shorted or grounded compressor	Shorted or grounded fan motor
High suction pressure	X	X	X	X	X	X	X	X	X	X	X	X	X	X	X
Low suction pressure	X	X	X	X	X	X	X	X	X	X	X	X	X	X	X
Unit runs continuously but insufficient cooling	X	X	X	X	X	X	X	X	X	X	X	X	X	X	X
Too cool	X	X	X	X	X	X	√	√	X	X	X	X	X	X	X
Compressor is noisy	X	X	X	X	X	X	X	X	X	X	X	X	X	X	X
Horizontal louver can not revolve	X	X	√	√	X	X	X	X	X	X	X	X	√	X	X
Test method/ remedy	Test voltage	Inspect fuse type & size	Inspect connections - tighten	Test circuits with tester	Test continuity of safety device	Test continuity of thermostat/ sensor & wiring	Place the temperature sensor at the central of the air inlet grille	Check control circuit with tester	Check capacitor with tester	Test continuity of coil & contacts	Test continuity of coil & contacts	Test voltage	Replace the stepping motor	Check resistance with multimeter	Check resistance with multimeter

# 5 TROUBLESHOOTING

## 5.5 Quick Maintenance by Error Code

If you do not have the time to test which specific parts are faulty, you can change the required parts according to the error code. You can find the parts to replace by error code in the following table.

Part Requiring Replacement	Error Code								
	EH 00/ EH 0A	EL 01	EH 03	EH 60	EH 61	EL 0C	EH C1/ EH C2	EH 0E	EH 0b
Indoor PCB	√	√	√	√	√	√	X	√	√
Outdoor PCB	X	√	X	X	X	X	X	X	X
Indoor Fan Motor	X	X	√	X	X	X	X	X	X
T1 Sensor	X	X	X	√	X	X	X	X	X
T2 Sensor	X	X	X	X	√	√	X	√	X
T2B Sensor	X	X	X	X	X	X	X	X	X
T2A sensor	X	X	X	X	X	X	X	X	X
Magnet Ring	X	√	X	X	X	X	X	X	X
Compressor	X	X	X	X	X	X	X	X	X
Additional Refrigerant	X	X	X	X	X	√	√	√	X
Water-Level Switch	X	X	X	X	X	X	X	√	X
Water Pump	X	X	X	X	X	X	X	√	X
Display Board	X	X	X	X	X	X	X	X	√

Part Requiring Replacement	Error Code											
	EC 54	EC 51	EC 52	EC 53	EC 56	EC 07	PC 00	PC 01	PC 02	PC 04	PC 03	FH CC/ EH C3
Indoor PCB	X	X	X	X	X	X	X	X	X	X	X	√
Outdoor PCB	√	√	√	√	√	√	√	√	√	√	√	X
Outdoor Fan Motor	X	X	X	X	X	√	√	X	√	√	X	X
T3 Sensor	X	X	√	X	X	X	X	X	X	X	X	X
T4 Sensor	X	X	X	√	X	X	X	X	X	X	X	X
TP Sensor	√	X	X	X	X	X	X	X	X	X	X	X
T2B Sensor	X	X	X	X	√	X	X	X	X	X	X	X
Refrigerant Sensor	X	X	X	X	X	X	X	X	X	X	X	√
Reactor Sensor	X	X	X	X	X	X	X	√	X	X	X	X
Compressor	X	X	X	X	X	X	√	X	X	√	X	X
IPM Module Board	X	X	X	X	X	X	√	√	√	√	X	X
Pressure Protector	X	X	X	X	X	X	X	X	X	X	√	X
Additional Refrigerant	X	X	X	X	X	X	X	X	X	X	√	X

## 5.6 Troubleshooting by Error Code

### EH 00/ EH 0A/ EC 51: EEPROM Malfunction Error Diagnosis and Solution.

**Description:** Indoor PCB main chip does not receive feedback from EEPROM chip.

**Recommended parts to prepare:**

- Indoor PCB
- Outdoor PCB

**Troubleshooting and repair:**

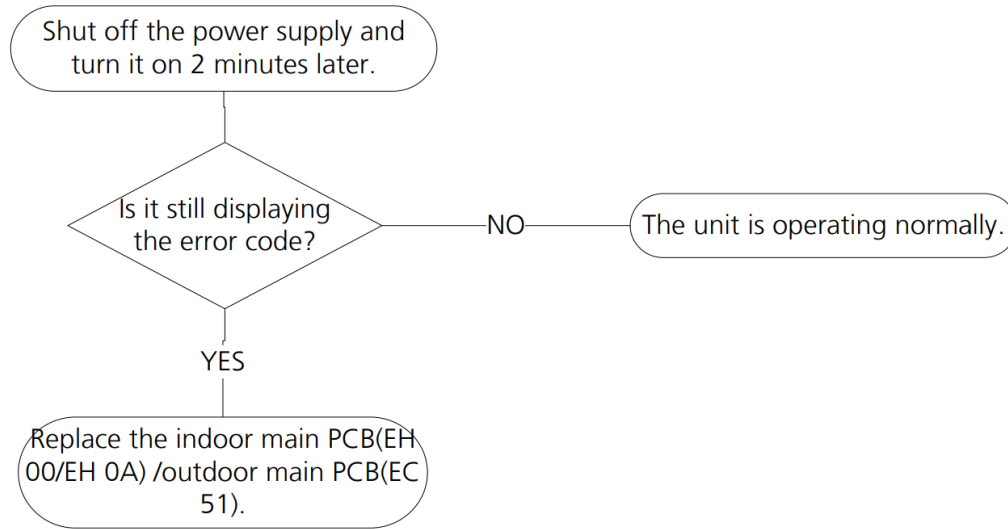

**Remarks:**

**EEPROM:** A read-only memory whose contents can be erased and reprogrammed using a pulsed voltage. The location of the EEPROM chip on the indoor PCB is shown in the following images:

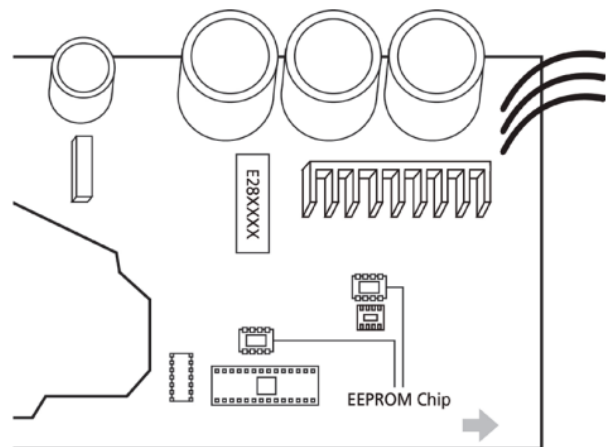
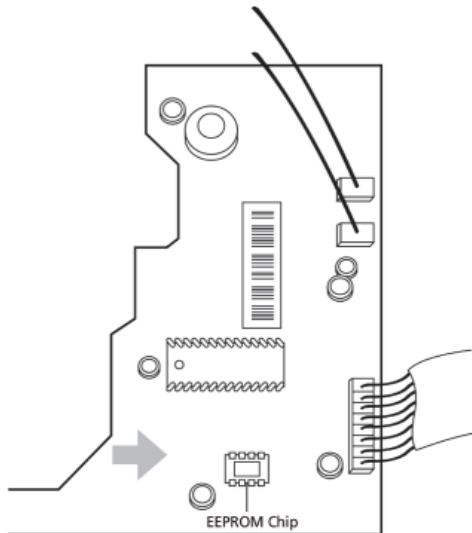

*Note: These pictures are for reference, actual appearance may vary.*

**Troubleshooting and repair of the compressor driven chip EEPROM parameter error and communication error between the outdoor main chip and compressor driven chip are the same as EC 51.**

# 5 TROUBLESHOOTING

## EL 01: IDU & ODU Communication Error Diagnosis and Solution.

**Description:** Indoor unit cannot communicate with the outdoor unit.

**Recommended parts to prepare:**

- Indoor PCB
- Outdoor PCB
- Reactor

**Troubleshooting and repair:**

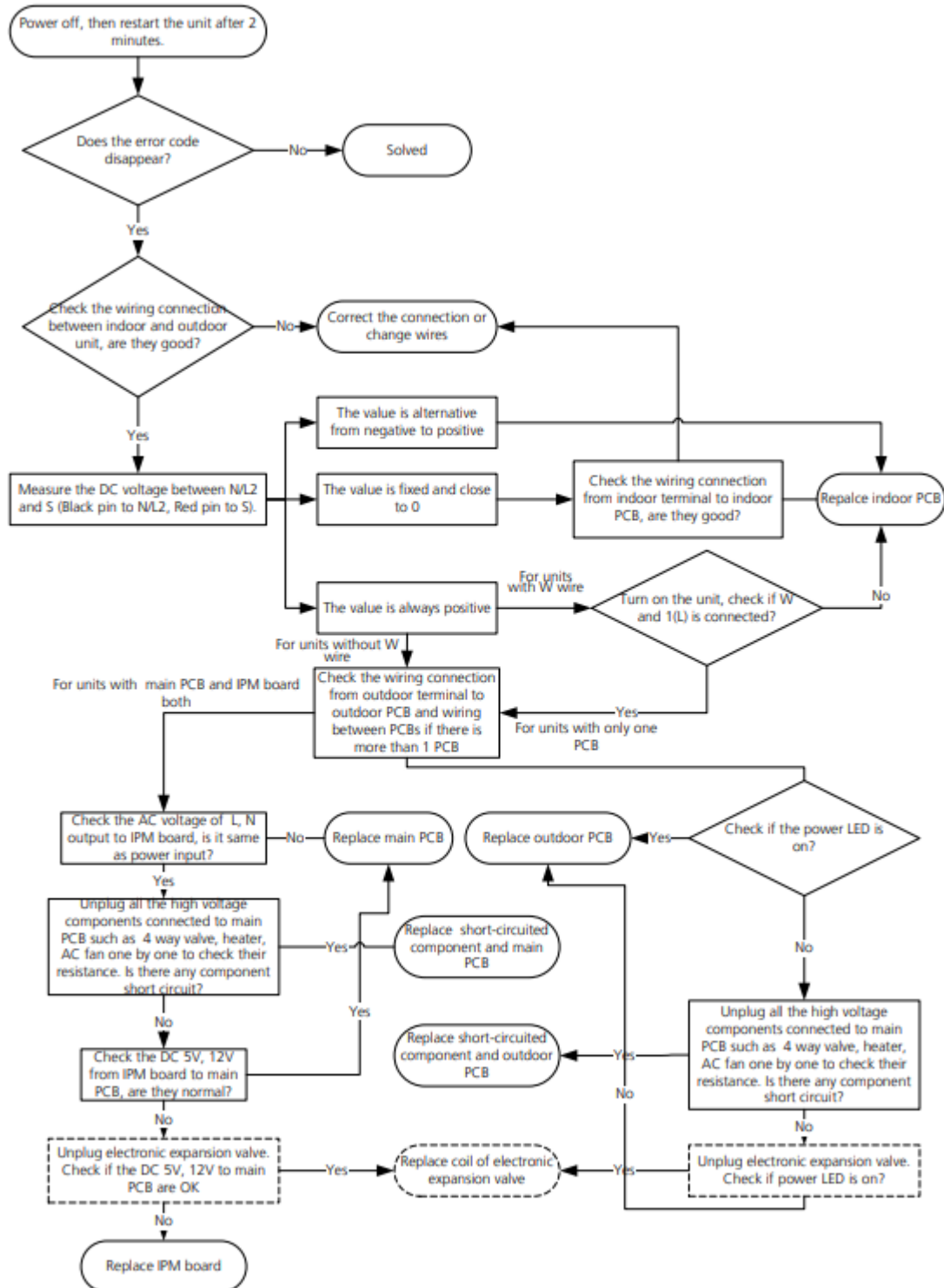

## EH 03/ EC 07: Fan Speed Out of Control Diagnosis and Solution.

**Description:** When the indoor/outdoor fan speed keeps too low or too high for a certain time, the unit ceases operation and the LED displays a fault.

### Recommended parts to prepare:

- Connection wires
- Fan assembly
- Fan motor
- PCB

### Troubleshooting and repair:

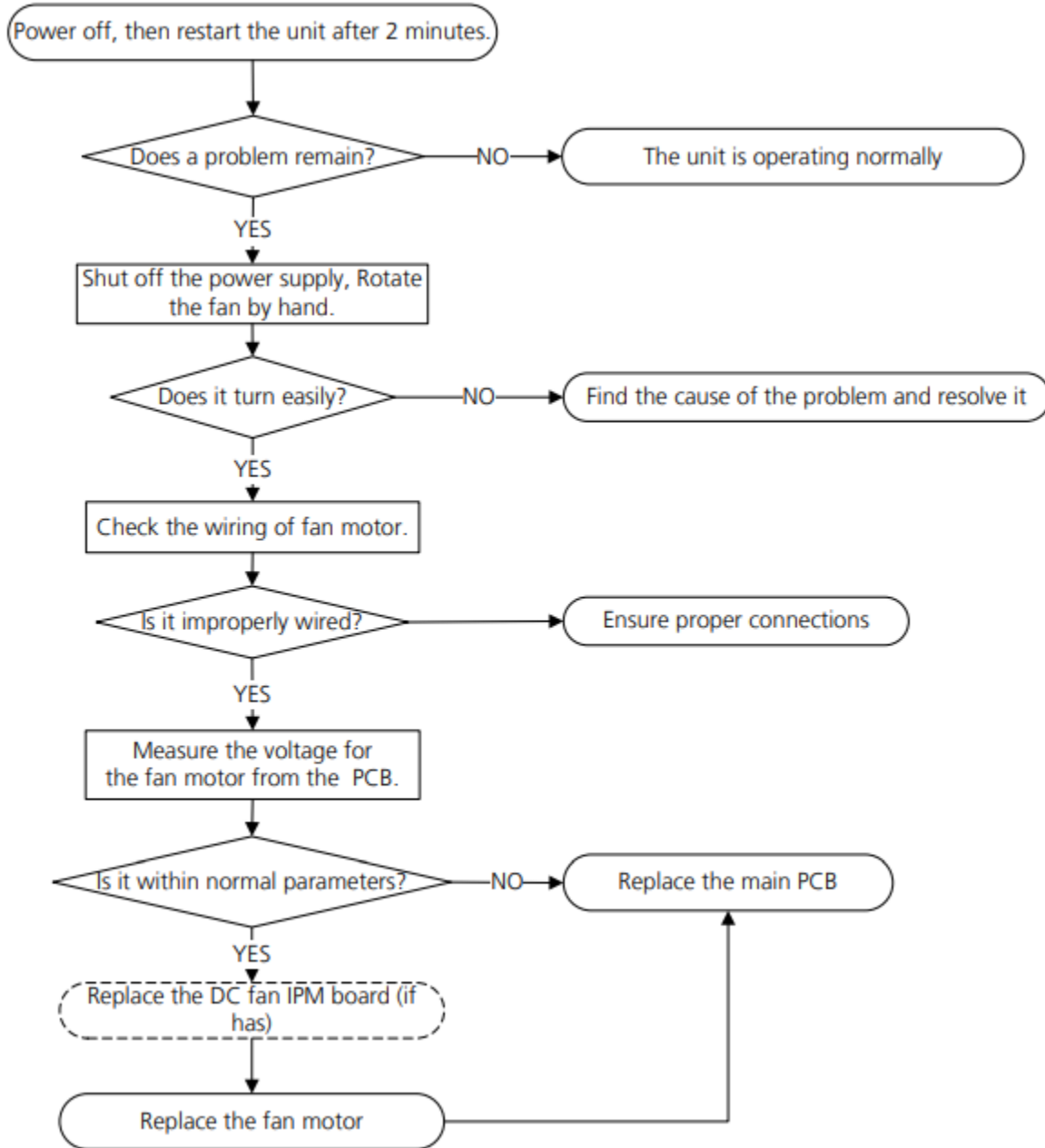

**Index:**

**1. Indoor or Outdoor DC fan motor (control chip is in fan motor)**

Power on and make sure the unit is in standby, measure the voltage of pin1-pin3, pin4-pin3 on the fan motor connector. If the value of the voltage is not in the range showing in the tables below the PCB will have problems and will need to be replaced.

NO.	Color	Signal	Voltage
1	Red	Vs/Vm	192V~380V
2	---	---	---
3	Black	GND	0V
4	White	Vcc	13.5-16.5V
5	Yellow	Vsp	0~6.5V
6	Blue	FG	13.5-16.5V

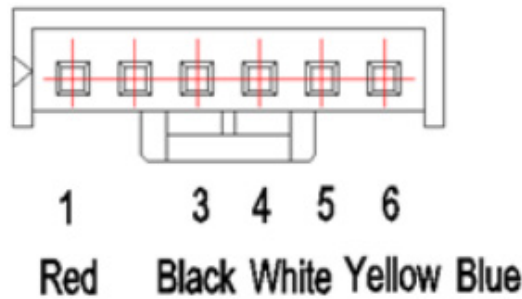

**Index:**

**1. Outdoor DC fan motor (control chip is in outdoor PCB)**

Release the UVW connector and measure the resistance of U-V, U-W, V-W. If the resistance is not equal to each other the fan motor has a problem and needs to be replaced. Otherwise the PCB has a problem and needs to be replaced.

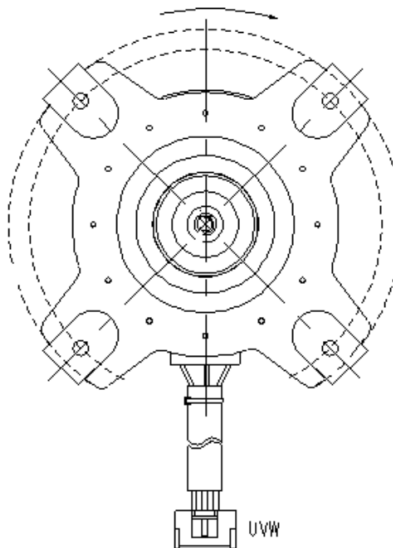

## EH 60/ EH 61/ EC 53/ EC 52/ EC 54/ EC 56: Open Circuit or Short Circuit of Temperature Sensor Diagnosis and Solution.

**Description:** If the sampling voltage is lower than 0.06V or higher than 4.94V, the LED displays a fault code.

### Recommended parts to prepare:

- Connection wires
- Sensors
- PCB

### Troubleshooting and repair:

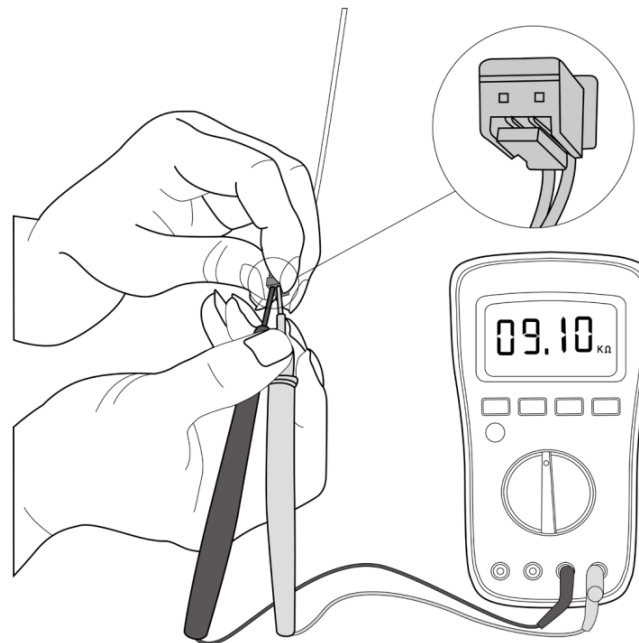
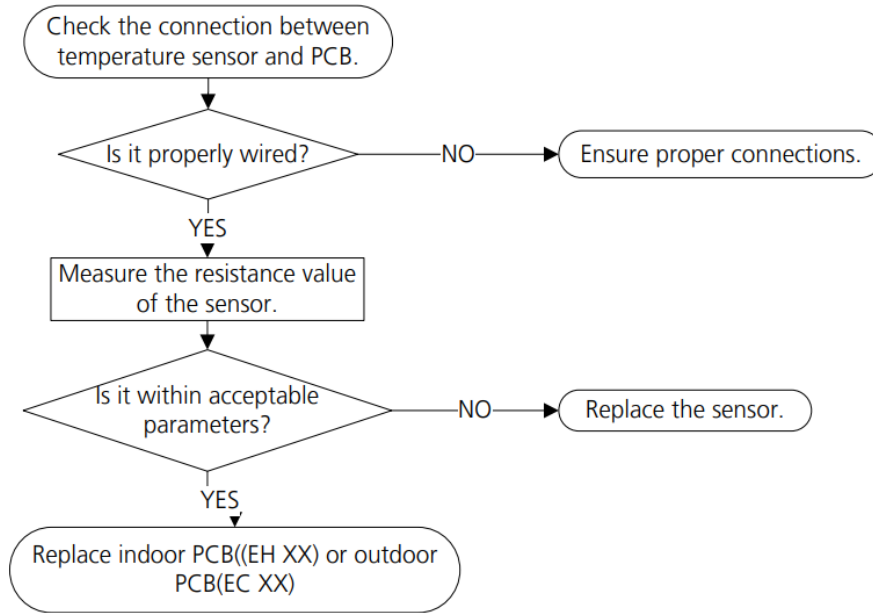

*Note: The picture and the value are for reference only, actual condition and specific values may vary.*

# 5 TROUBLESHOOTING

## EL 0C: System Lacks Refrigerant Diagnosis and Solution.

**Description:** Judging the abnormality of the refrigeration system according to the number of compressor stops and the changes in operating parameters caused by excessive exhaust temperature.

### Recommended parts to prepare:

- Indoor PCB
- Additional refrigerant

### Troubleshooting and repair:

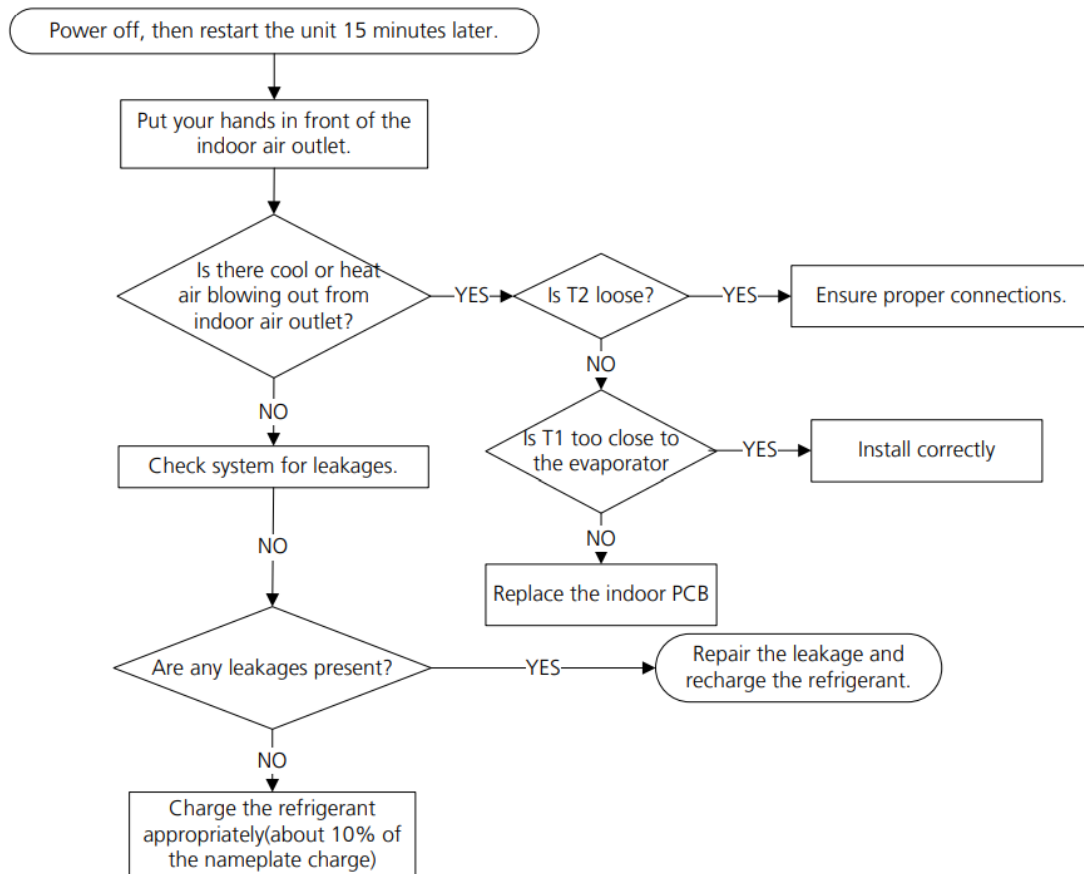

## EH 0E: Water-Level Alarm Malfunction Diagnosis and Solution.

**Description:** If the sampling voltage is not 5V, the LED displays a fault code.

**Recommended parts to prepare:**

- Connection wires
- Water-level switch
- Water pump
- Indoor PCB

**Troubleshooting and repair:**

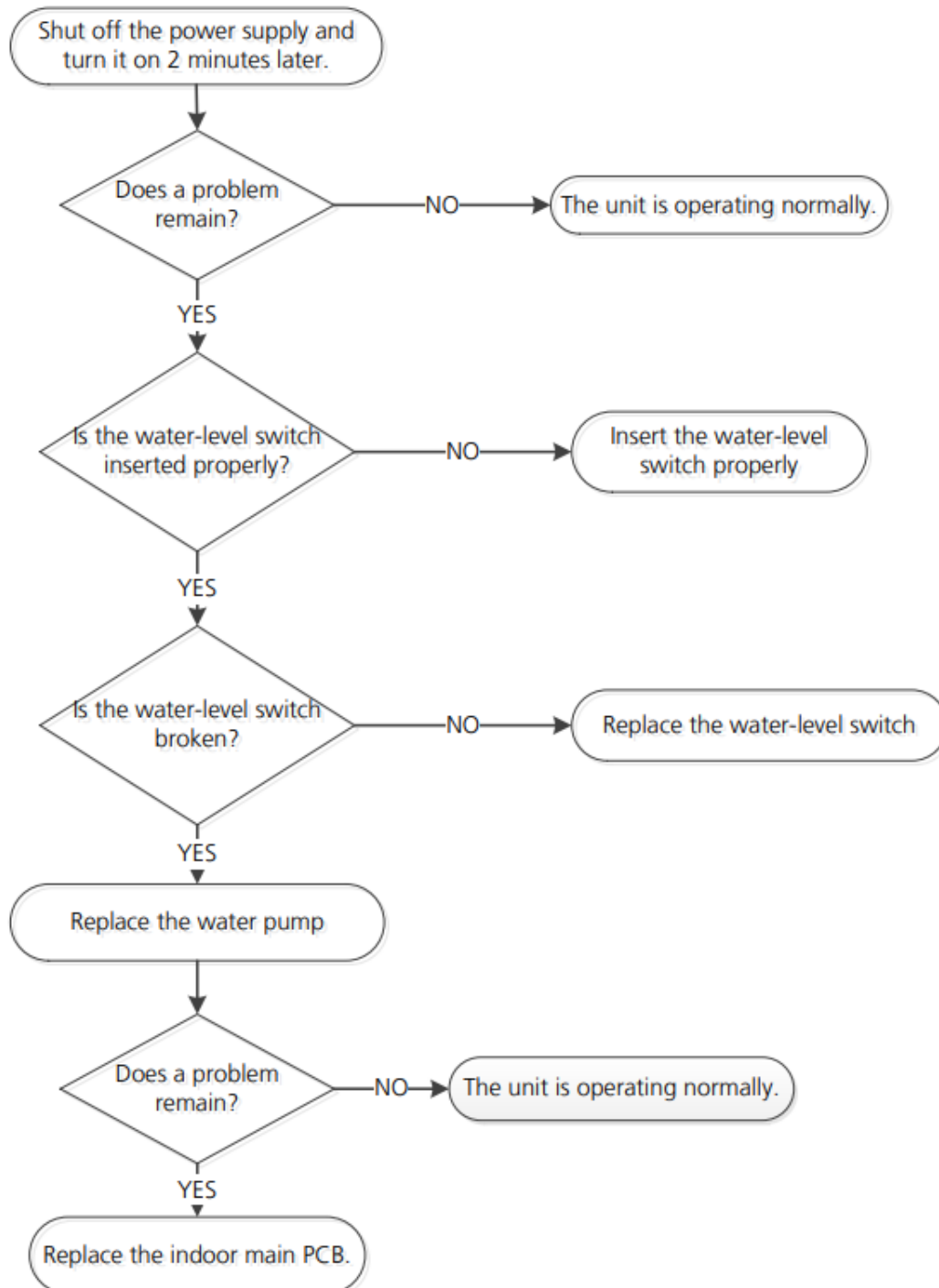

# 5 TROUBLESHOOTING

## PC 00: ODU IPM Module Protection Diagnosis and Solution.

**Description:** When the voltage signal the IPM sends to the compressor drive chip is abnormal, the LED displays a fault code.

### Recommended parts to prepare:

- Connection wires
- IPM module board
- Outdoor fan assembly
- Compressor
- Outdoor PCB

### Troubleshooting and repair:

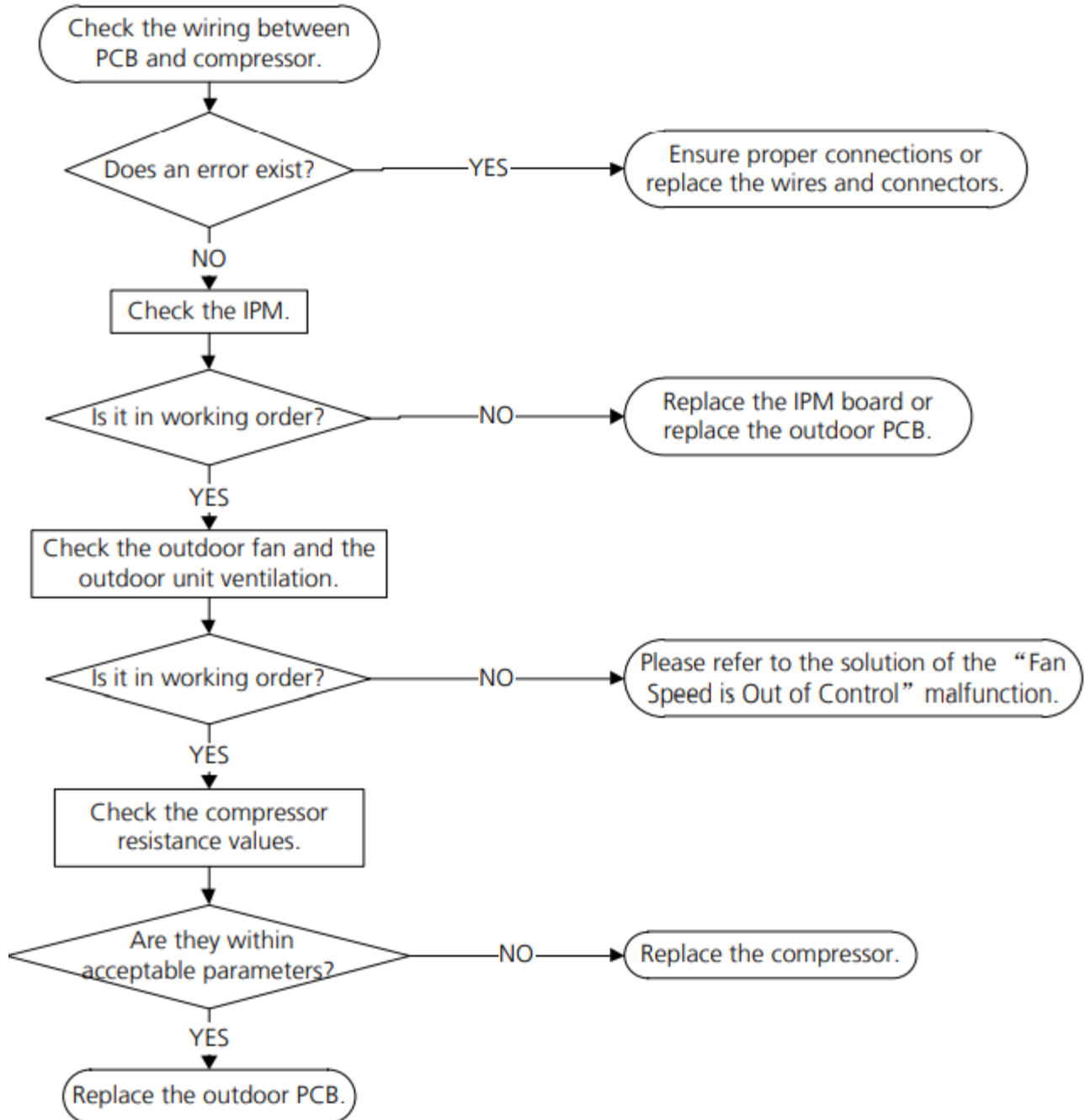

## PC 01: ODU Voltage Protection Diagnosis and Solution.

**Description:** Abnormal increases or decreases in voltage are detected by checking the specified voltage detection circuit.

**Recommended parts to prepare:**

- Power supply wires
- IPM module board
- PCB
- Reactor

**Troubleshooting and repair:**

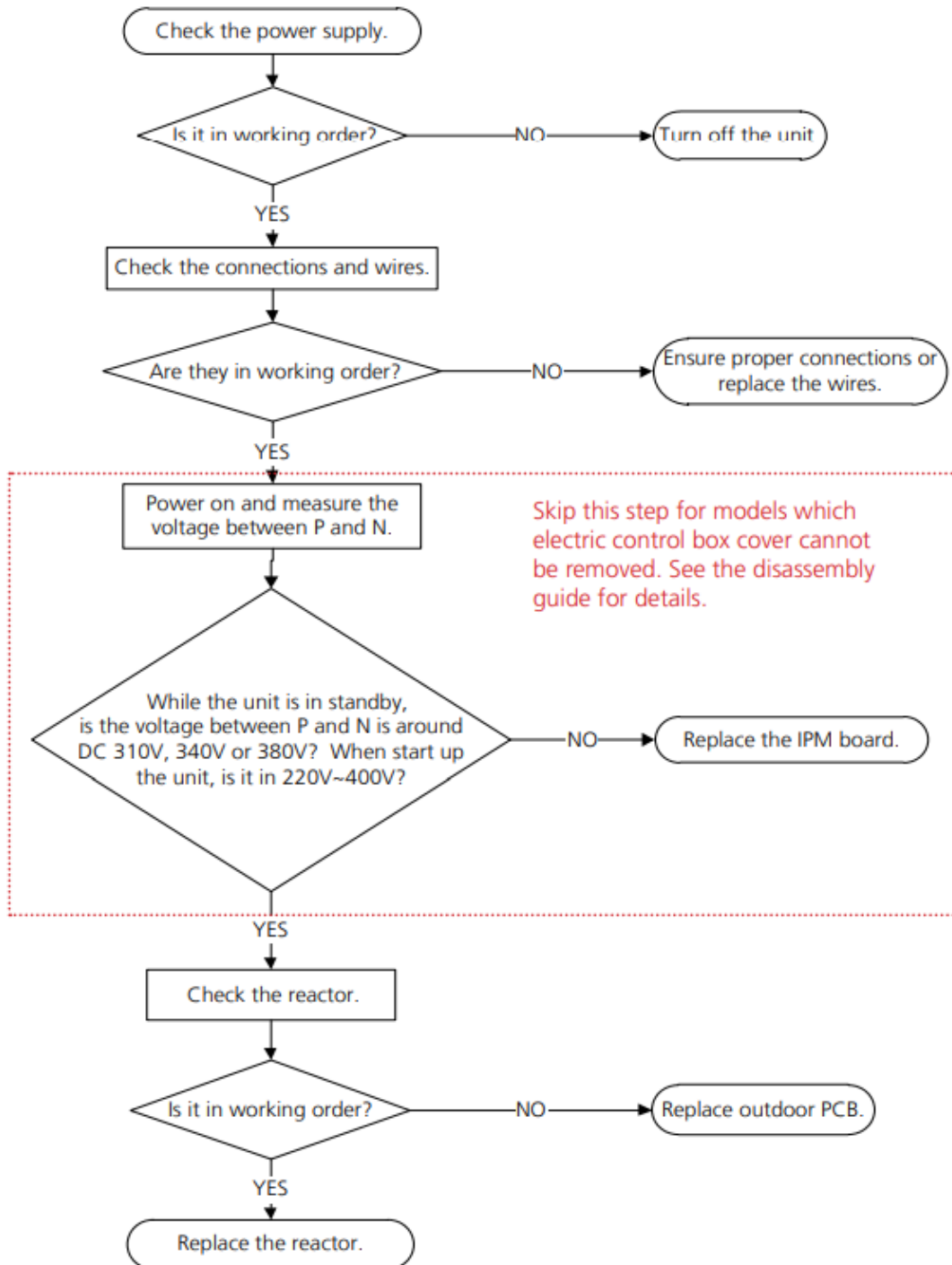

## PC 04: Inverter Compressor Drive Error Diagnosis and Solution.

**Description:** An abnormal inverter compressor drive is detected by a special detection circuit, including communication, signal detection, voltage detection, compressor rotation speed signal detection, and so on.

### Recommended parts to prepare:

- Connection wires
- IPM module board
- Outdoor fan assembly
- Compressor
- Outdoor PCB

### Troubleshooting and repair:

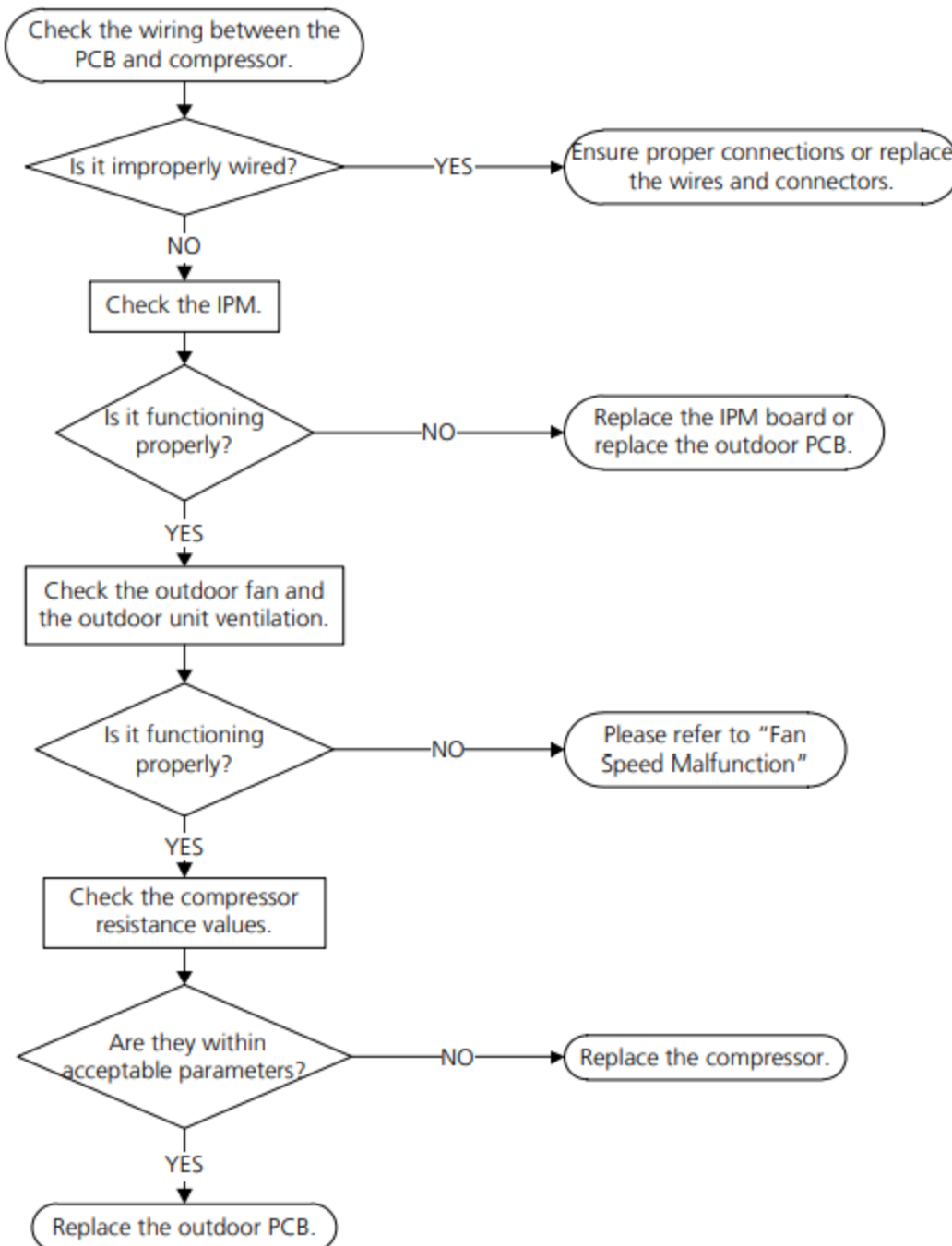

## PC 03: Pressure Protection (Low or High Pressure) Diagnosis and Solution.

**Description:** The outdoor pressure switch cut off the system due to high pressure (if pressure is higher than 638 PSI.(4.4MPa)). Or the outdoor pressure switch cut off the system due to low pressure (if the pressure is lower than 18.85 PSI.(0.13MPa) the LED will display a fault code.

### Recommended parts to prepare:

- Connection wires
- Pressure switch
- Outdoor fan
- Outdoor main PCB
- Refrigerant

### Troubleshooting and repair:

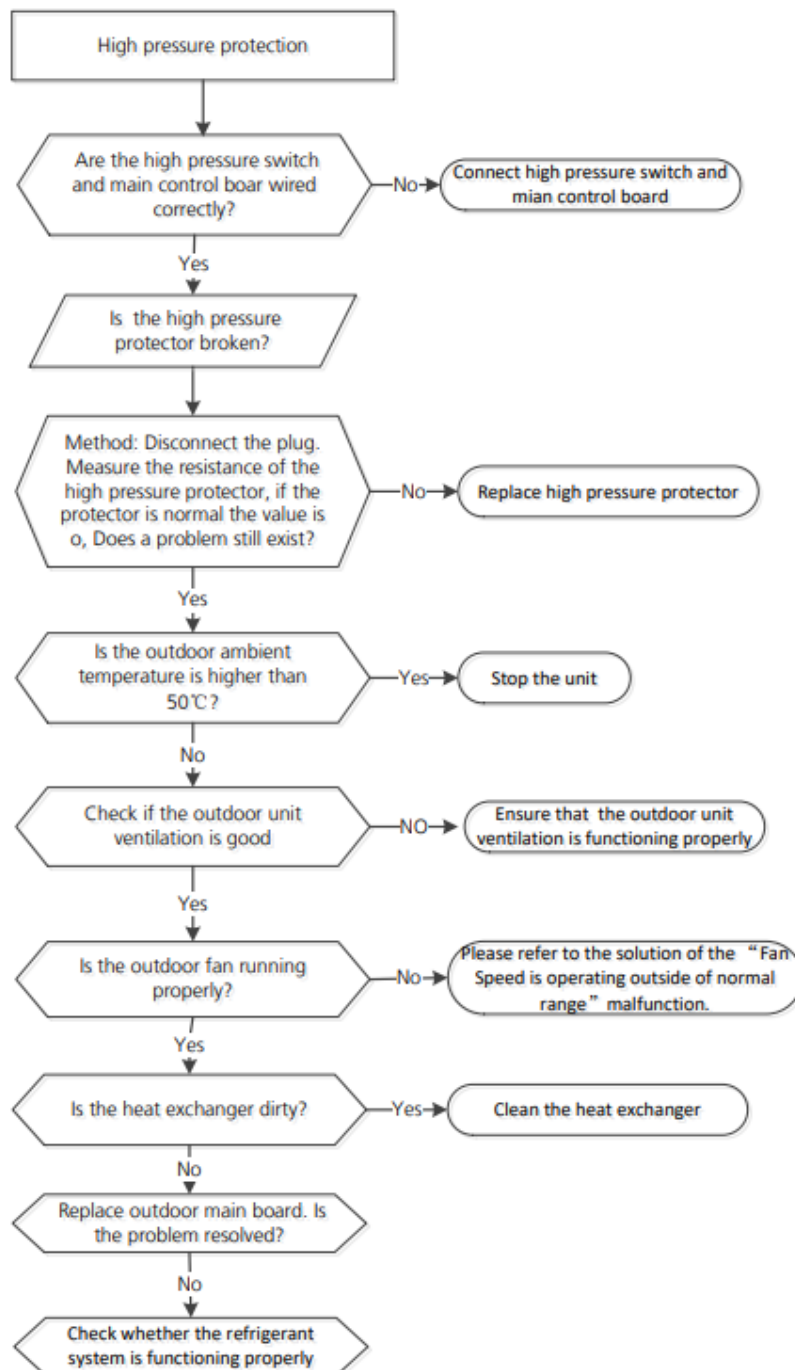

## PC 03: Cont.

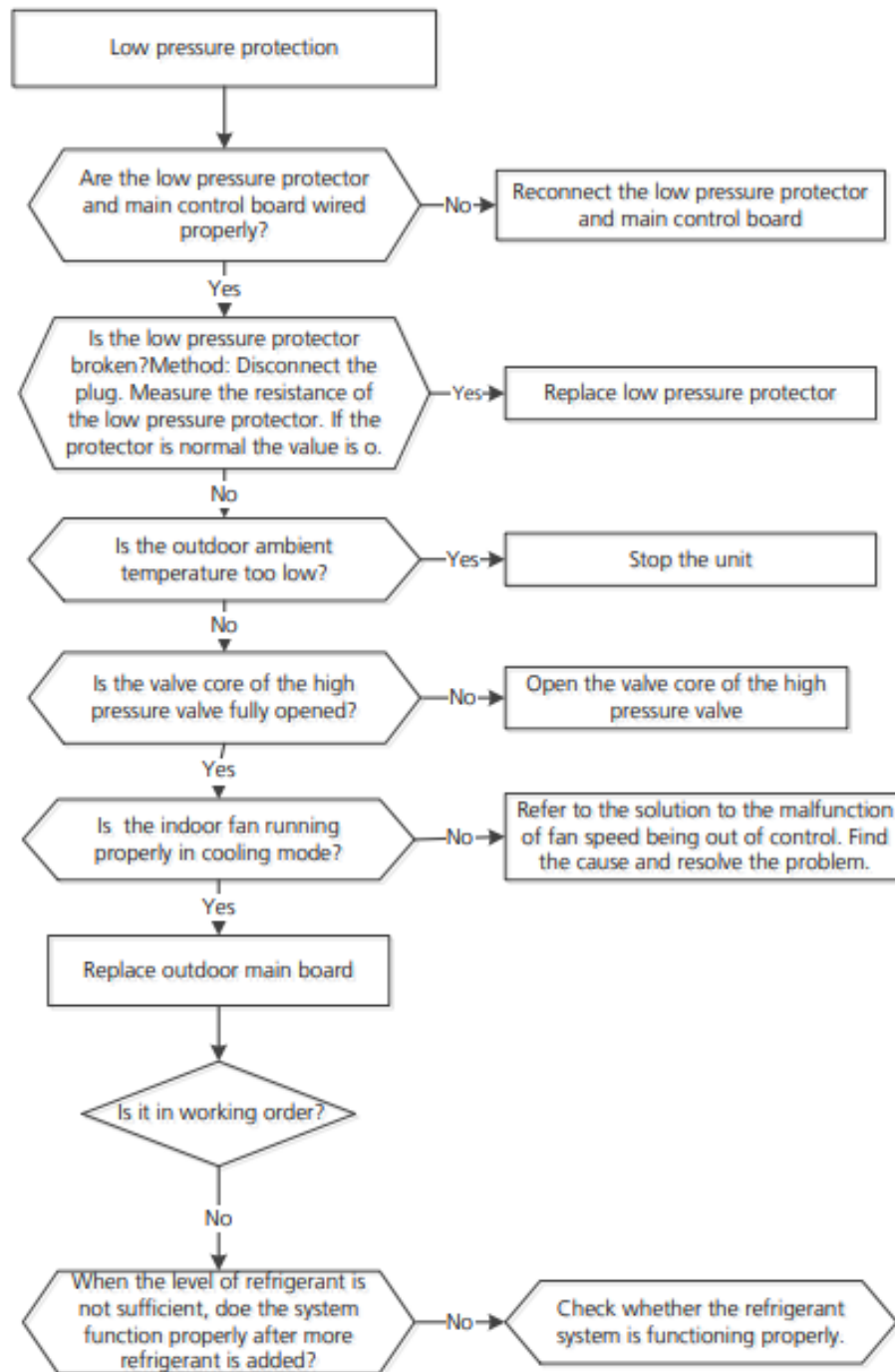

## PC 02: Compressor Top (or IPM) Temp. Protection Diagnosis and Solution.

**Description:** (For some models with overload protection). If the sampling voltage is not 5V, the LED will display a fault code. If the temperature of the IPM module is higher than a certain value, the LED will display a fault code.

### Recommended parts to prepare:

- Connection wires
- Outdoor PCB
- IPM module board
- High pressure protector
- System blockages

### Troubleshooting and repair:

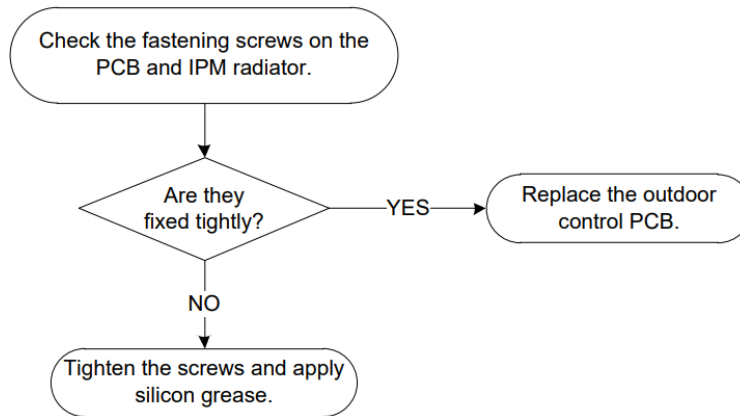
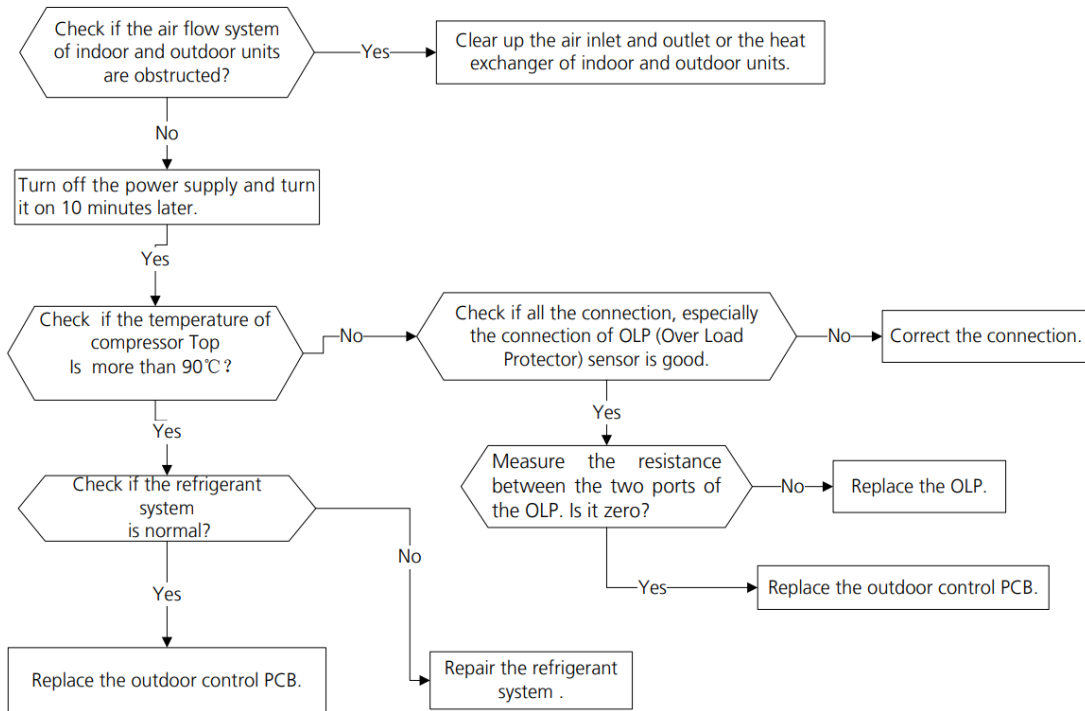

# 5 TROUBLESHOOTING

## PC 0L: Low Ambient Temperature Protection.

**Description:** It is a protection function. When the compressor is off and the outdoor ambient temperature (T4) is lower than  $-35^{\circ}\text{C}$  for 10s, the AC will stop and display the fault code. When the compressor is on and the outdoor ambient temperature (T4) is lower than  $-40^{\circ}\text{C}$  for 10s, the AC will stop and display the fault code. When the outdoor ambient temperature (T4) is no lower than  $-32^{\circ}\text{C}$  for 10s, the unit will exit the protection.

## EH b3: Communication malfunction Between Wire and Master Control Diagnosis and Solution.

**Description:** If the indoor PCB does not receive feedback from the wired controller, the error displays on the wired controller..

### Recommended parts to prepare:

- Connection wires
- Indoor PCB
- Wired Controller

### Troubleshooting and repair:

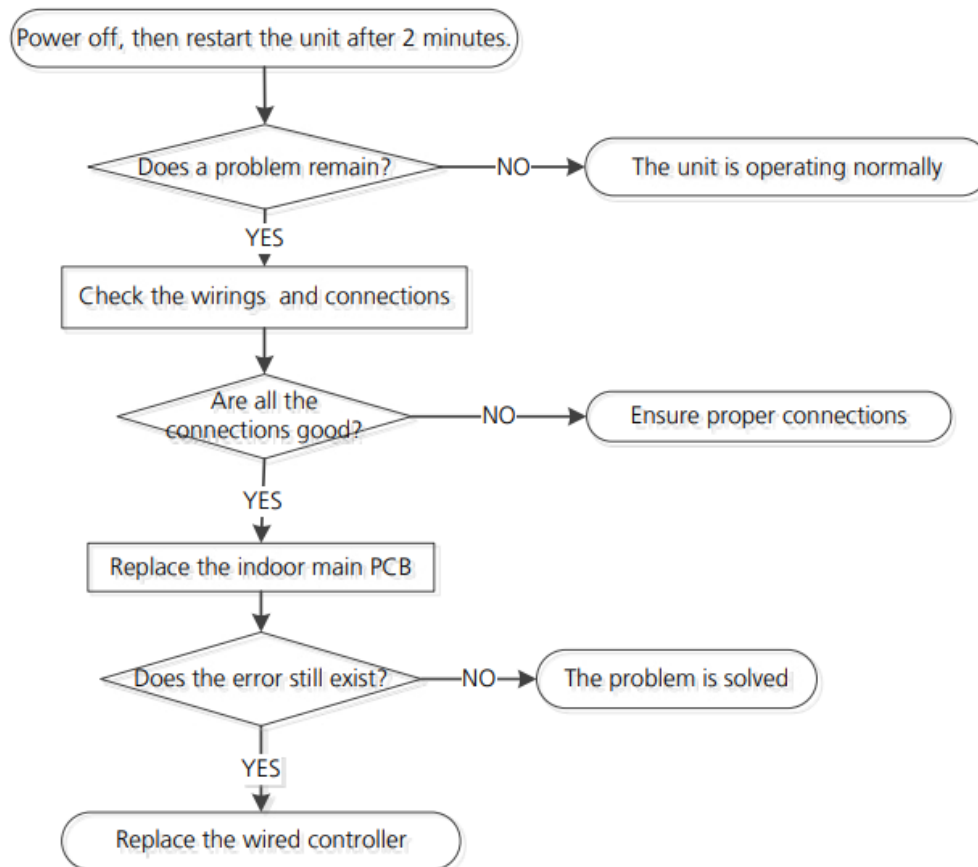

## EH bA: Communication Error Between the Indoor Unit and the External Fan module/ EH 3A: External Fan DC Bus Voltage is too Low Protection/ EH 3b: External fan DC bus voltage is too High Fault Diagnosis and Solution.

**Description:** The indoor unit does not receive the feedback from the external fan module during 150s or the indoor unit receives abnormal increases or decreases in voltage from the external fan module.

### Recommended parts to prepare:

- Indoor main PCB

### Troubleshooting and repair:

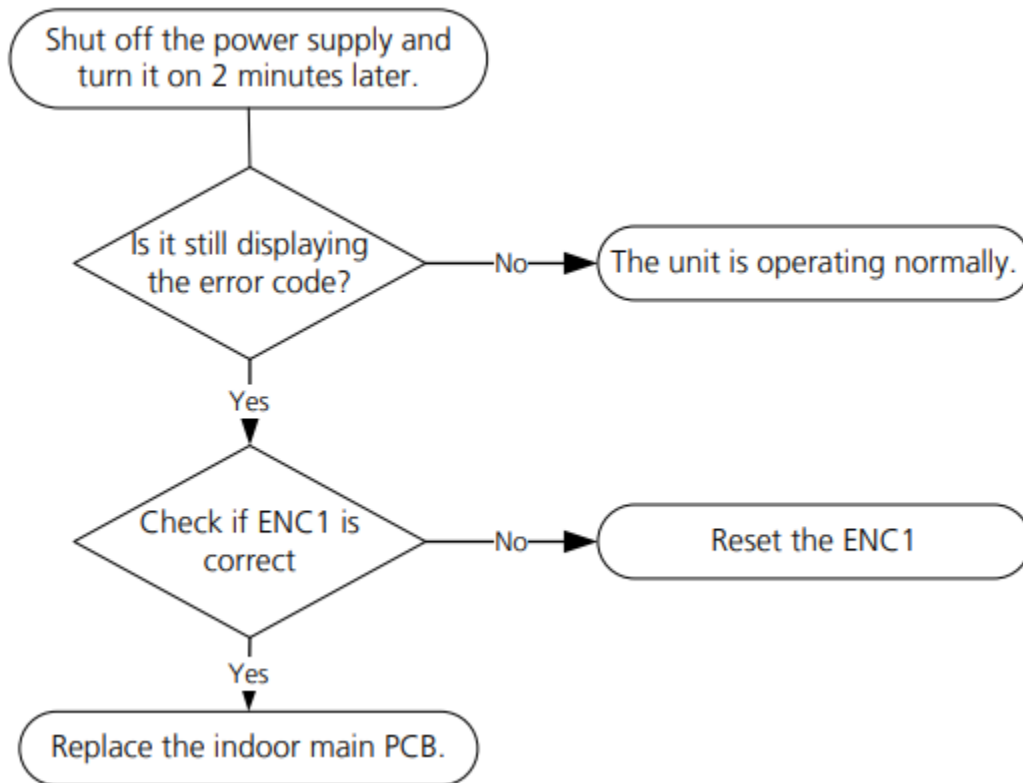

# 5 TROUBLESHOOTING

## FH CC: Refrigerant Sensor Error/ EH C3: Refrigerant Sensor is Out of Range Diagnosis and Solution.

**Description:** Indoor unit receives a fault signal for 10s or the indoor unit does not receive feedback from the refrigerant sensor for 150s.

### Recommended parts to prepare:

- Connection wires
- Sensors
- Indoor main PCB

### Troubleshooting and repair:

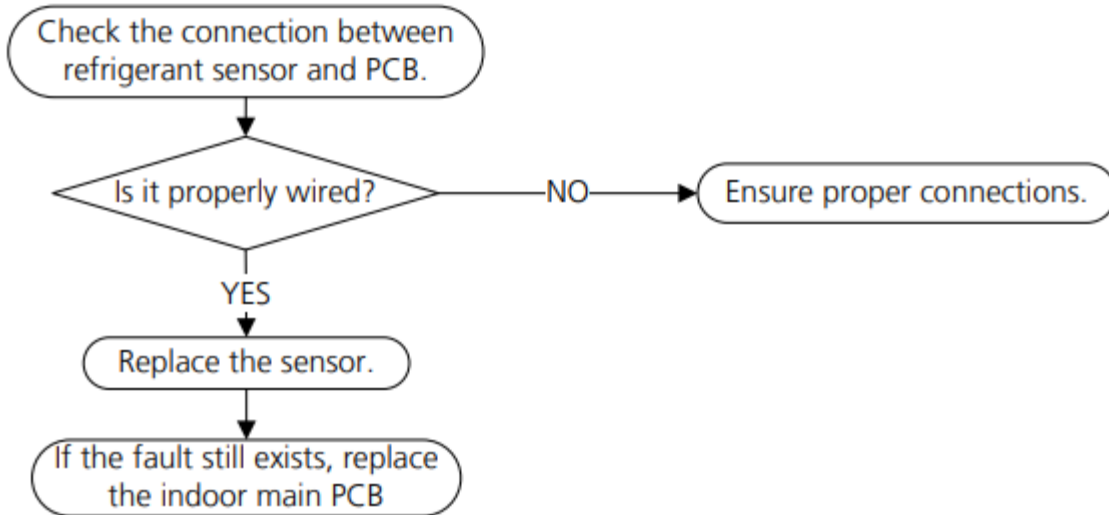

## EH C1: Refrigerant Sensor Detects Leakage/ EH C2: Refrigerant Sensor is Out of Range and Leakage is Detected Diagnosis and Solution

**Description:** The refrigerant sensor detects a concentration higher than or equal to 10%\*LFL for 10 seconds or the refrigerant sensor detects a concentration higher than or equal to 20%\*LFL or the multi model receives the refrigerant leakage protection fault sent by the outdoor unit.

**Multi-zone:** Only the buzzer of the indoor unit that detects refrigerant leakage continues to sound the alarm, the shortest sound is 10 seconds and the longest sound is 5 minutes (you can press any key on the remote control, wired controller, APP, and so on to eliminate the alarm) and any other non-refrigerant leakage fault the indoor unit will only display ECC1 and the buzzer will not make a sound.

### Recommended parts to prepare:

- Additional refrigerant

### Troubleshooting and repair:

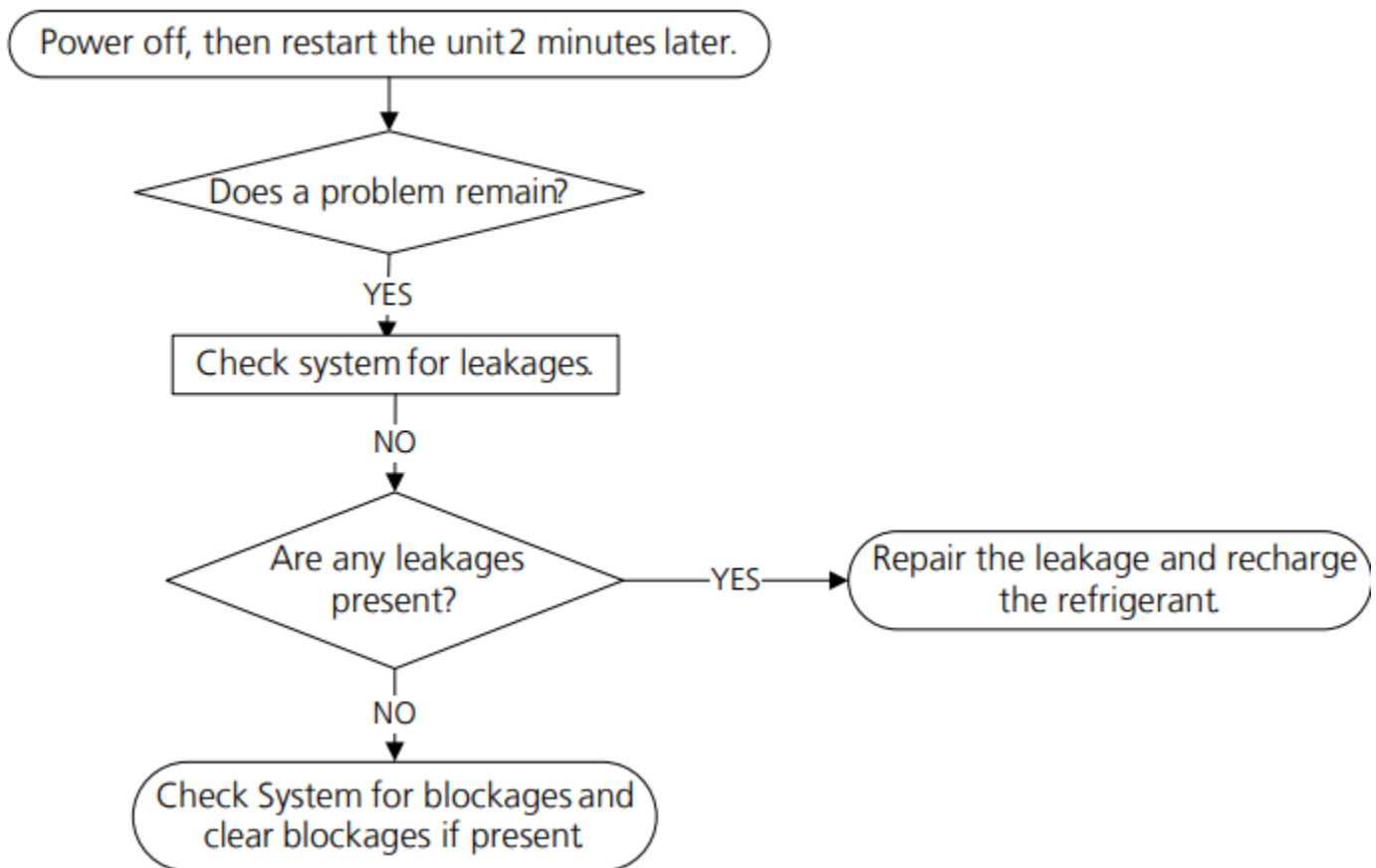

# 5 TROUBLESHOOTING

## EC 0d: ODU malfunction diagnosis and solution.

**Description:** The indoor unit detect the outdoor is having an error.

**Recommended parts to prepare:**

- Outdoor unit

**Troubleshooting and repair:**

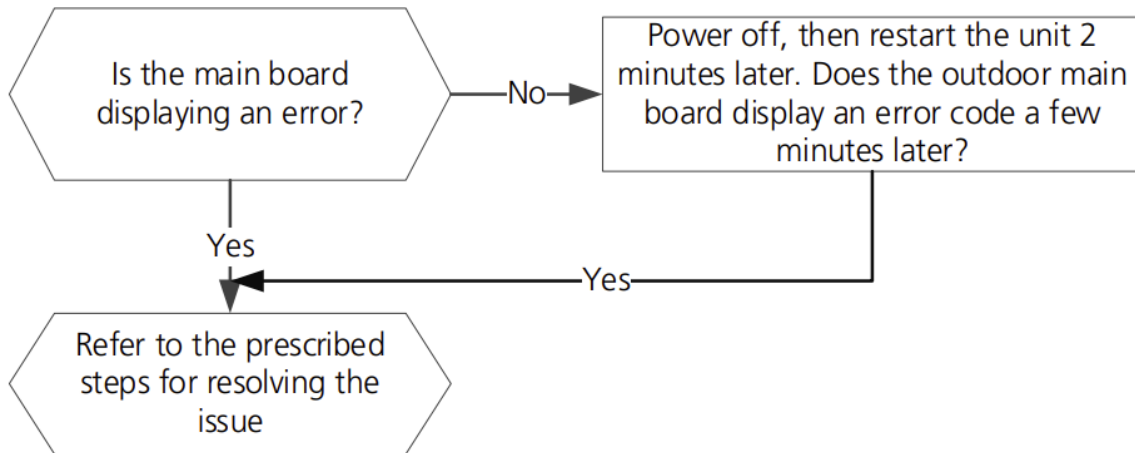

## EH 0b: IDU main control board and display board communication error diagnosis and solution.

**Description:** Indoor PCB does not receive feedback from the display board.

**Recommended parts to prepare:**

- Communication wire
- Indoor PCB
- Display board

**Troubleshooting and repair:**

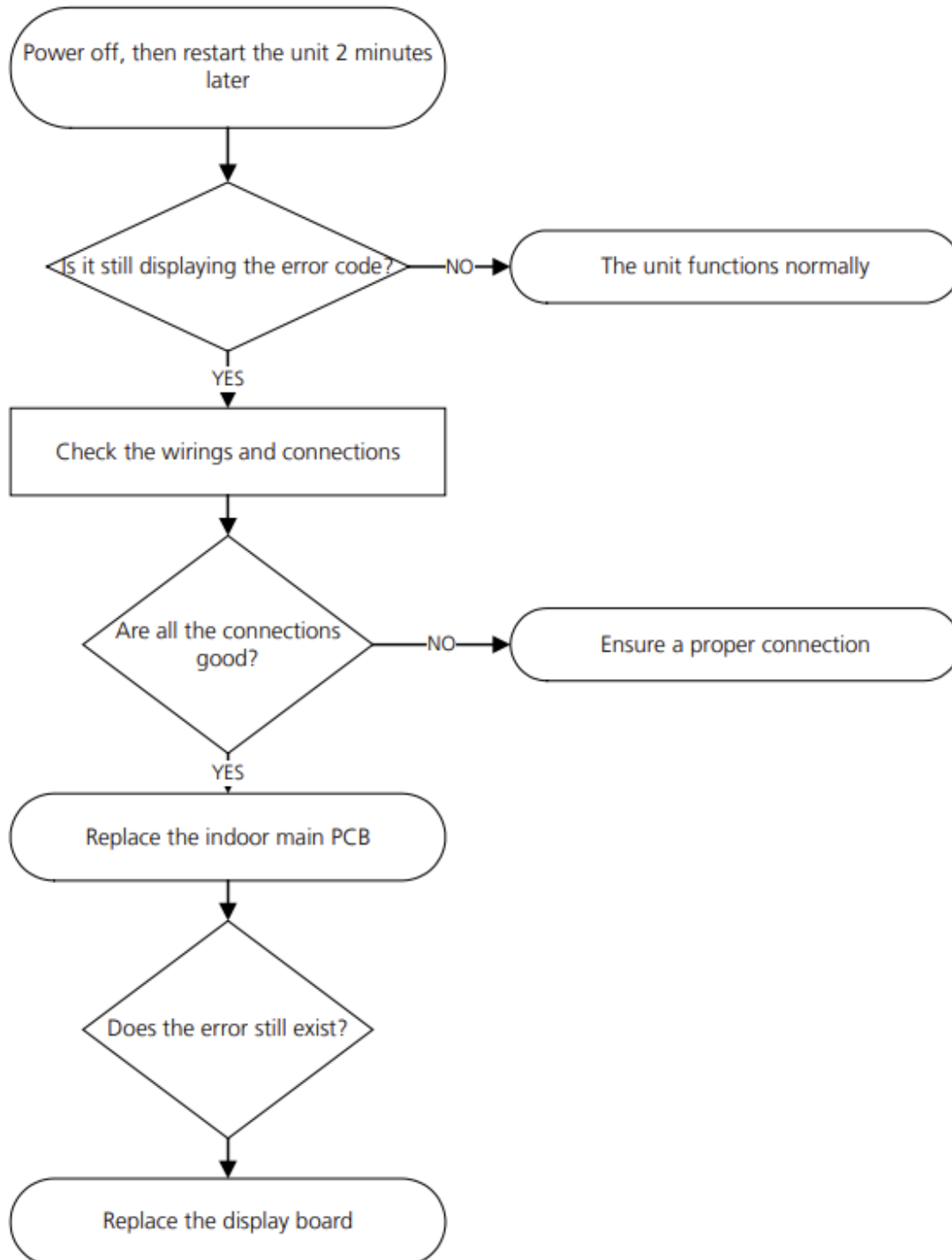

# 5 TROUBLESHOOTING

## EL 16: Communication malfunction between adapter board and outdoor main board diagnosis and solution.

**Description:** The adapter PCB cannot detect the main control board.

### Recommended parts to prepare:

- Connection wires
- Adapter board
- Outdoor main PCB

### Troubleshooting and repair:

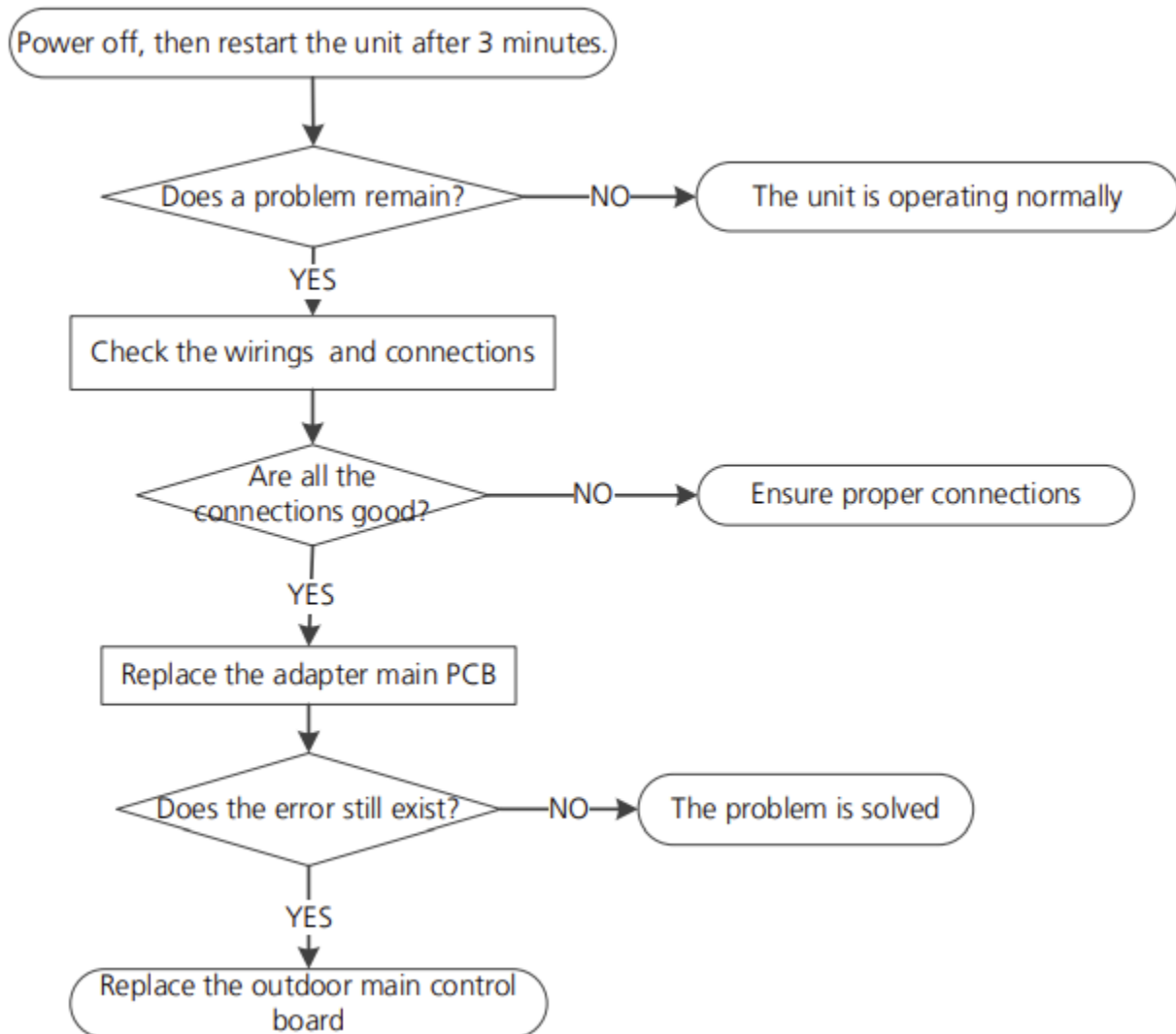

## FL 09: Mismatch between the new and old platforms diagnosis and solution.

**Description:** Indoor and outdoor units are mismatched, the LED displays this code. Please replace the matching indoor or outdoor unit.

## 5.7 Check Procedures

### WARNING

Be sure to turn off all power supplies or disconnect all wires to avoid electric shock. Operate only after the compressor and coil has returned to normal temperature in case of injury.

### Temperature Sensor Check:

1. Disconnect the temperature sensor from the PCB.
2. Measure the resistance value of the sensor using a multi-meter.
3. Check corresponding temperature sensor resistance value table.

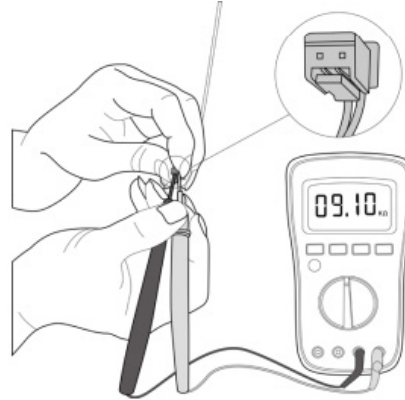

*Note: The picture and the value are for reference only, actual condition and specific values may vary.*

# 6 TEMPERATURE SENSOR RESISTANCE TABLE

Temperature Sensor Resistance Value Table (°C-K)

°C	°F	K Ohm	°C	°F	K Ohm	°C	°F	K Ohm	°C	°F	K Ohm
-20	-4	542.7	20	68	68.66	60	140	13.59	100	212	3.702
-19	-2	511.9	21	70	65.62	61	142	13.11	101	214	3.595
-18	0	483	22	72	62.73	62	144	12.65	102	216	3.492
-17	1	455.9	23	73	59.98	63	145	12.21	103	217	3.392
-16	3	430.5	24	75	57.37	64	147	11.79	104	219	3.296
-15	5	406.7	25	77	54.89	65	149	11.38	105	221	3.203
-14	7	384.3	26	79	52.53	66	151	10.99	106	223	3.113
-13	9	363.3	27	81	50.28	67	153	10.61	107	225	3.025
-12	10	343.6	28	82	48.14	68	154	10.25	108	226	2.941
-11	12	325.1	29	84	46.11	69	156	9.902	109	228	2.86
-10	14	307.7	30	86	44.17	70	158	9.569	110	230	2.781
-9	16	291.3	31	88	42.33	71	160	9.248	111	232	2.704
-8	18	275.9	32	90	40.57	72	162	8.94	112	234	2.63
-7	19	261.4	33	91	38.89	73	163	8.643	113	235	2.559
-6	21	247.8	34	93	37.3	74	165	8.358	114	237	2.489
-5	23	234.9	35	95	35.78	75	167	8.084	115	239	2.422
-4	25	222.8	36	97	34.32	76	169	7.82	116	241	2.357
-3	27	211.4	37	99	32.94	77	171	7.566	117	243	2.294
-2	28	200.7	38	100	31.62	78	172	7.321	118	244	2.233
-1	30	190.5	39	102	30.36	79	174	7.086	119	246	2.174
0	32	180.9	40	104	29.15	80	176	6.859	120	248	2.117
1	34	171.9	41	106	28	81	178	6.641	121	250	2.061
2	36	163.3	42	108	26.9	82	180	6.43	122	252	2.007
3	37	155.2	43	109	25.86	83	181	6.228	123	253	1.955
4	39	147.6	44	111	24.85	84	183	6.033	124	255	1.905
5	41	140.4	45	113	23.89	85	185	5.844	125	257	1.856
6	43	133.5	46	115	22.89	86	187	5.663	126	259	1.808
7	45	127.1	47	117	22.1	87	189	5.488	127	261	1.762
8	46	121	48	118	21.26	88	190	5.32	128	262	1.717
9	48	115.2	49	120	20.46	89	192	5.157	129	264	1.674
10	50	109.8	50	122	19.69	90	194	5	130	266	1.632
11	52	104.6	51	124	18.96	91	196	4.849			
12	54	99.69	52	126	18.26	92	198	4.703			
13	55	95.05	53	127	17.58	93	199	4.562			
14	57	90.66	54	129	16.94	94	201	4.426			
15	59	86.49	55	131	16.32	95	203	4.294			
16	61	82.54	56	133	15.73	96	205	4.167			
17	63	78.79	57	135	15.16	97	207	4.045			
18	64	75.24	58	136	14.62	98	208	3.927			
19	66	71.86	59	138	14.09	99	210	3.812			

# 6 TEMPERATURE SENSOR RESISTANCE TABLE

## Other Temperature Sensor Resistance Value Table (°C-K)

°C	°F	K Ohm	°C	°F	K Ohm	°C	°F	K Ohm	°C	°F	K Ohm
-20	-4	115.266	20	68	12.6431	60	140	2.35774	100	212	0.62973
-19	-2	108.146	21	70	12.0561	61	142	2.27249	101	214	0.61148
-18	0	101.517	22	72	11.5	62	144	2.19073	102	216	0.59386
-17	1	96.3423	23	73	10.9731	63	145	2.11241	103	217	0.57683
-16	3	89.5865	24	75	10.4736	64	147	2.03732	104	219	0.56038
-15	5	84.219	25	77	10	65	149	1.96532	105	221	0.54448
-14	7	79.311	26	79	9.55074	66	151	1.89627	106	223	0.52912
-13	9	74.536	27	81	9.12445	67	153	1.89627	107	225	0.51426
-12	10	70.1698	28	82	8.71983	68	154	1.83003	108	226	0.49989
-11	12	66.0898	29	84	8.3356	69	156	1.76647	109	228	0.486
-10	14	62.2756	30	86	7.97078	70	158	1.70547	110	230	0.47256
-9	16	58.7079	31	88	7.62411	71	160	1.64691	111	232	0.45957
-8	18	56.3694	32	90	7.29464	72	162	1.59068	112	234	0.44699
-7	19	52.2438	33	91	6.98142	73	163	1.53668	113	235	0.43482
-6	21	49.3161	34	93	6.68355	74	165	1.48481	114	237	0.42304
-5	23	46.5725	35	95	6.40021	75	167	1.43498	115	239	0.41164
-4	25	44	36	97	6.13059	76	169	1.38703	116	241	0.4006
-3	27	41.5878	37	99	5.87359	77	171	1.34105	117	243	0.38991
-2	28	39.8239	38	100	5.62961	78	172	1.29078	118	244	0.37956
-1	30	37.1988	39	102	5.3689	79	174	1.25423	119	246	0.36954
0	32	35.2024	40	104	5.17519	80	176	1.2133	120	248	0.35982
1	34	33.3269	41	106	4.96392	81	178	1.17393	121	250	0.35042
2	36	31.5635	42	108	4.76253	82	180	1.13604	122	252	0.3413
3	37	29.9058	43	109	4.5705	83	181	1.09958	123	253	0.33246
4	39	28.3459	44	111	4.38736	84	183	1.06448	124	255	0.3239
5	41	26.8778	45	113	4.21263	85	185	1.03069	125	257	0.31559
6	43	25.4954	46	115	4.04589	86	187	0.99815	126	259	0.30754
7	45	24.1932	47	117	3.88673	87	189	0.96681	127	261	0.29974
8	46	22.5662	48	118	3.73476	88	190	0.93662	128	262	0.29216
9	48	21.8094	49	120	3.58962	89	192	0.90753	129	264	0.28482
10	50	20.7184	50	122	3.45097	90	194	0.8795	130	266	0.2777
11	52	19.6891	51	124	3.31847	91	196	0.85248	131	268	0.27078
12	54	18.7177	52	126	3.19183	92	198	0.82643	132	270	0.26408
13	55	17.8005	53	127	3.07075	93	199	0.80132	133	271	0.25757
14	57	16.9341	54	129	2.95896	94	201	0.77709	134	273	0.25125
15	59	16.1156	55	131	2.84421	95	203	0.7537	135	275	0.24512
16	61	15.3418	56	133	2.73823	96	205	0.73119	136	277	0.23916
17	63	14.6181	57	135	2.63682	97	207	0.68844	137	279	0.23338
18	64	13.918	58	136	2.53973	98	208	0.66818	138	280	0.22776
19	66	13.2631	59	138	2.4467	99	210	0.64862	139	282	0.22231

# 7 SYSTEM PRESSURE TABLE

## System Pressure Table-R454B

Pressure			Temperature		Pressure			Temperature	
Kpa	Bar	PSI	°C	°F	Kpa	Bar	PSI	°C	°F
58.196	0.58	8.44	-60	-76	935.23	9.35	135.64	8	46.4
61.517	0.62	8.92	-59	-74.2	963.75	9.64	139.78	9	48.2
64.988	0.65	9.43	-58	-72.4	992.93	9.93	144.01	10	50
68.615	0.69	9.95	-57	-70.6	1022.8	10.23	148.34	11	51.8
72.402	.072	10.50	-56	-68.8	1053.3	10.53	152.76	12	53.6
76.354	0.76	11.07	-55	-67	1084.5	10.85	157.29	13	55.4
80.478	0.80	11.67	-54	-65.2	1116.4	11.16	161.91	14	57.2
84.776	0.85	12.30	-53	-63.4	1149	11.49	166.64	15	59
89.256	0.89	12.95	-52	-61.6	1182.3	11.82	171.47	16	60.8
93.923	0.94	13.62	-51	-59.8	1216.3	12.16	176.40	17	62.6
98.781	0.99	14.33	-50	-58	1251.1	12.51	181.45	18	64.4
103.84	1.04	15.06	-49	-56.2	1286.6	12.87	186.60	19	66.2
109.1	1.09	15.82	-48	-54.4	1322.8	13.23	191.85	20	68
114.56	1.15	16.61	-47	-52.6	1359.9	13.60	197.23	21	69.8
120.25	1.20	17.44	-46	-50.8	1397.7	13.98	202.71	22	71.6
126.15	1.26	18.30	-45	-49	1436.3	14.36	208.31	23	73.4
132.28	1.32	19.18	-44	-47.2	1475.7	14.76	214.02	24	75.2
138.64	1.39	20.11	-43	-45.4	1515.9	15.16	219.85	25	77
145.24	1.45	21.06	-42	-43.6	1557	15.57	225.82	26	78.8
152.09	1.52	22.06	-41	-41.8	1598.9	15.99	231.89	27	80.6
159.18	1.59	23.09	-40	-40	1641.6	16.42	238.09	28	82.4
166.54	1.67	24.15	-39	-38.2	1685.2	16.85	244.41	29	84.2
174.15	1.74	25.26	-38	-36.4	1729.7	17.30	250.86	30	86
182.04	1.82	26.40	-37	-34.6	1775	17.75	257.43	31	87.8
190.2	1.90	27.59	-36	-32.8	1821.3	18.21	264.15	32	89.6
198.65	1.99	28.81	-35	-31	1868.4	18.68	270.98	33	91.4
207.39	2.07	30.08	-34	-29.2	1916.5	19.17	277.95	34	93.2
216.42	2.16	31.39	-33	-27.4	1965.6	19.66	285.08	35	95
225.76	2.26	32.74	-32	-25.6	2015.5	20.16	292.31	36	96.8
235.41	2.35	34.14	-31	-23.8	2066.5	20.67	299.71	37	98.6
245.37	2.45	35.59	-30	-22	2118.4	21.18	307.24	38	100.4
255.67	2.56	37.08	-29	-20.2	2171.3	21.71	314.19	39	102.2
266.29	2.66	38.62	-28	-18.4	2225.2	22.25	322.73	40	104
277.25	2.77	40.21	-27	-16.6	2280.2	22.80	330.70	41	105.8
288.56	2.89	41.85	-26	-14.8	2336.1	23.36	338.81	42	107.6
300.22	3.00	43.54	-25	-13	2393.2	23.93	347.09	43	109.4
312.24	3.12	45.28	-24	-11.2	2451.3	24.51	355.52	44	111.2
324.63	3.25	47.08	-23	-9.4	2510.4	25.10	364.09	45	113
337.39	3.37	48.93	-22	-7.6	2570.7	25.71	372.84	46	114.8
350.54	3.51	50.84	-21	-5.8	2632.1	26.32	381.74	47	116.6
364.08	3.64	52.80	-20	-4	2694.7	26.95	390.82	48	118.4
378.02	3.78	54.83	-19	-2.2	2758.33	27.58	400.04	49	120.2
392.37	3.92	56.91	-18	-0.4	2823.2	28.23	409.46	50	122
407.13	4.07	59.05	-17	1.4	2889.3	28.89	419.04	51	123.8

## System Pressure Table-R454B Cont.

Pressure			Temperature		Pressure			Temperature	
Kpa	Bar	PSI	°C	°F	Kpa	Bar	PSI	°C	°F
422.31	4.22	61.25	-16	3.2	2956.5	29.57	428.79	52	125.6
437.92	4.38	63.5	-15	5	3025	30.25	438.72	53	127.4
453.98	4.54	65.84	-14	6.8	3094.7	30.95	448.83	54	129.2
470.47	4.70	68.23	-13	8.6	3165.7	31.66	459.13	55	131
487.43	4.87	70.69	-12	10.4	3238.1	32.38	469.63	56	132.8
504.84	5.05	73.22	-11	12.2	3311.7	33.12	480.30	57	134.6
522.73	5.23	75.81	-10	14	3386.7	33.87	491.18	58	136.4
541.1	5.41	78.48	-9	15.8	3463	34.63	502.25	59	138.2
559.95	5.60	81.21	-8	17.6	3540.7	35.41	513.52	60	140
579.31	5.79	84.02	-7	19.4	3619.9	36.20	525.00	61	141.8
599.16	5.99	86.90	-6	21.2	3700.5	37.01	536.69	62	143.6
619.54	6.20	89.85	-5	23	3782.7	37.83	548.61	63	145.4
640.43	6.40	92.88	-4	24.8	3866.3	38.66	560.74	64	147.2
661.86	6.62	95.99	-3	26.6	3951.5	39.52	573.10	65	149
683.82	6.84	99.18	-2	28.4	4038.3	40.38	585.69	66	150.8
706.34	7.06	102.44	-1	30.2	4126.8	41.27	598.52	67	152.6
729.41	7.29	105.79	0	32	4217	42.17	611.60	68	154.4
753.06	7.53	109.22	1	33.8	4309	43.09	624.95	69	156.2
777.28	7.77	112.73	2	35.6	4402.9	44.03	638.56	70	158
802.08	8.02	116.33	3	37.4	4498.7	44.99	652.46	71	159.8
827.47	8.27	120.01	4	39.2	4596.5	45.97	666.64	72	161.6
853.49	8.53	123.78	5	41	4696.5	46.97	681.15	73	163.4
880.11	8.80	127.64	6	42.8	4798.9	47.99	696.00	74	165.5
907.35	9.07	131.60	7	44.6	4904.1	49.04	711.25	75	167



**MRCOOL®**

COMFORT MADE SIMPLE

**MRCOOL®**

# **Pre-Charged Coil**

## Service Manual

The design and specifications of this product and/or manual are subject to change without prior notice.  
Consult with the sales agency or manufacturer for details.