

Job Name:	
Submitted By:	



Submittal Sheet For: **WT012GLSI24HLG / YN012GLSI24RPG**

Date _____
 Ref. _____

Wall-Mounted Ductless 24SEER Inverter Heat Pump

System Full Set Model: **WYT012GLSI24RL**

AHRI Reference Number: **217048751**

Cooling Mode Performance

Rated Cooling	12,000 BTU/hr
Ambient Range	5~131°F
SEER2 Rating	24 BTU/W·h
EER2 Rating	13 BTU/W·h

* 100% Capacity @ Indoor DB 80°F / WB 67°F

Heating Mode Performance

Rated Heating	12,600 BTU/hr
Ambient Range	-13~86°F
HSPF2 IV (V)	10 (8.6) BTU/W·h
COP2 (47°F)	3.81 W/W

Low Heat (17°F) = 10,000 BTU / COP2 (5°F) = 2.1 W/W

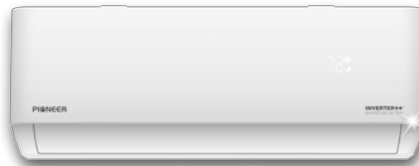

Wall-Mounted Indoor Unit



Outdoor Condensing Unit



User-Selected Installation Kit



Handheld Remote Controller

Electrical Information

	Cooling	Heating
Rated Input (W)	970	925
Rated Current (A)	4.4	4.2
Breaker Needed	15A (Double-Pole)	
Power Supply	208~230V, 1Ph, 60Hz	

Piping and Refrigerant

Liquid Line (OD)	1/4 in
Suction Line (OD)	3/8 in
Refrigerant Precharge	R-454b(Supports 10-50ft.)
Max Length/Height Diff.	50 ft. / 33 ft.

This combination is Energy-Star certified.



Interior Unit (Air Handler) Specifications

Type	Heat Pump
Sound Level (dBA)	46 (Turbo)/ 44 (Hi)/ 36 (Med)/ 32 (Lo)/ 30 (Mute)
Auto Air Circulation	2-Way Louver (Up-Down + Left-Right)
Dimensions (WDH)	36-1/4 in x 7-5/8 in x 12 in
Weight (lbs)	23.1

Exterior Unit (Condenser) Specifications

Sound Level (dBA)	52
Recommended Room Size	350~500 Sq. ft.
Minimum Room Size	40 Sq. ft.
Compressor	Inverter-Driven Rotary
Dimensions (WDH)	31-7/8 in x 12 in x 21-5/8 in
Weight (lbs)	58.4

WT012GLSI24HLG Air Handler Dimensional Data

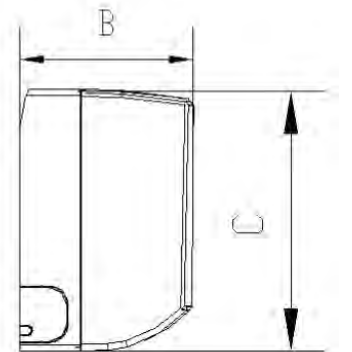
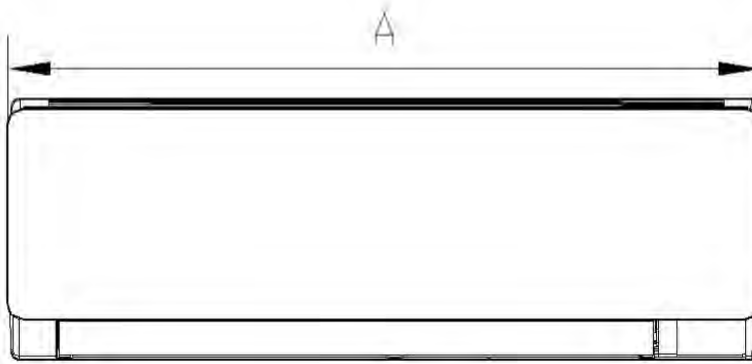
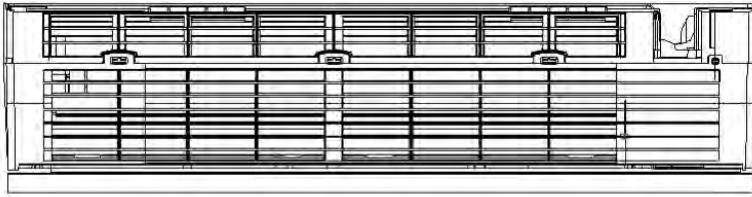

Model	A	B	C
WT012GLSI24HLG	36-1/4 in	7-3/4 in	12 in
	920 mm	195.3 mm	304.8 mm

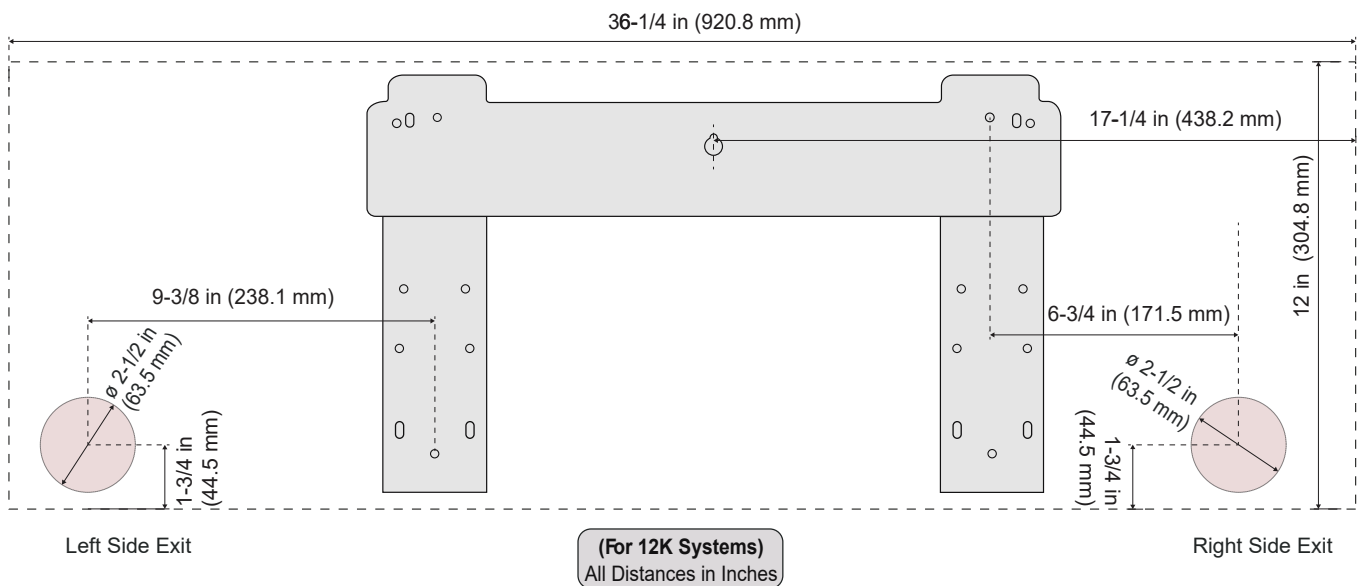

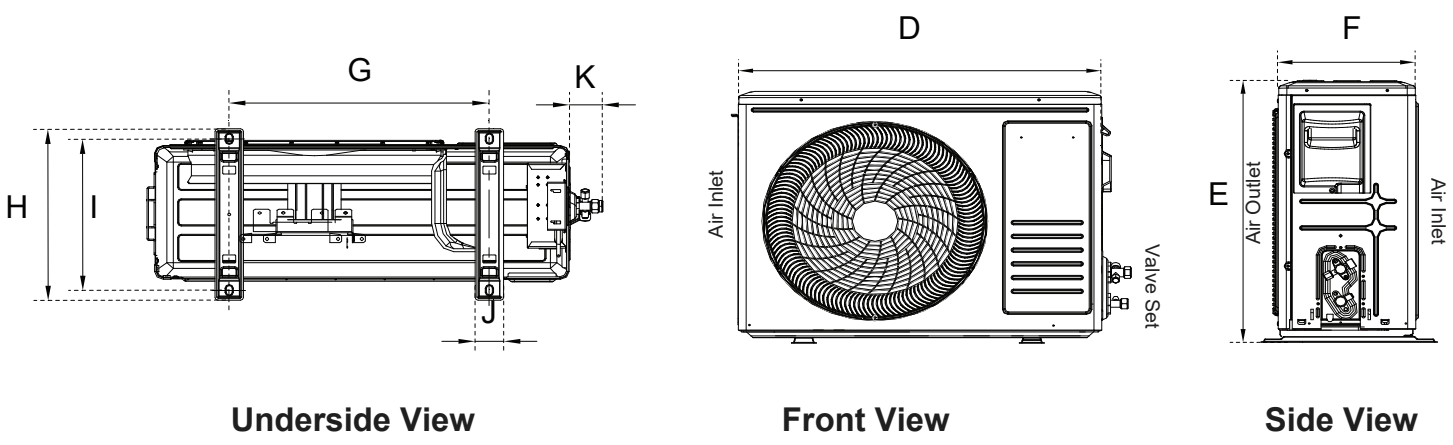

Model	D	E	F	G	H	I	J	K
YN012GLSI24RPG	29-1/8 in	21-3/4 in	10 in	17-1/8 in	12 in	11-1/4 in	1-7/8 in	2-1/4 in
	741 mm	551 mm	253 mm	434 mm	304.8 mm	285 mm	48 mm	58 mm

Warranty Information and Length



Complete warranty details are available with the vendor or online at <https://www.pdhvac.com/support/warranty/>. This high quality system is eligible for up to 10 years limited warranty on the compressor, and 7 years on other internal parts. To qualify for this warranty, the system must be installed within 90 days by a registered technician. All other installations that are registered default to 5 years parts/compressor. Products unregistered qualify for only 1 year parts/compressor warranty.

Outstanding Features

- LED Display
- Energy Saving
- Ultra-Thin Design
- Dual Drain Options
- Customizable Timer
- Eco-Friendly Refrigerant
- Whisper-Quiet Operation
- Power Loss Memory Recovery



Available Accessories

Part Number	Description
IKT-LCVR4P-KIT	<i>Decorative PVC Line Cover Kit</i>
IKT-LNBR-1/4-3/8	<i>BendAid Flexible Easy Bender Kit</i>
BRK-FRM-C-2P	<i>Folding Mounting Bracket w/ Leveler</i>
IKT-UVL32UL-AG	<i>UVC Bacterial Disinfection Kit</i>
IKT-SURPRK-DV2	<i>Ultimate Surge and Power Protection</i>