

Job Name:	
Submitted By:	



Submittal Sheet For:	RT018GLSILCFHG / YN018GLSI24RPG
-----------------------------	--

Date _____
 Ref. _____

Ceiling-Concealed Ducted 20SEER Inverter Heat Pump

System Full Set Model: **RYT018GLSI24RL**

AHRI Reference Number: **217048764**

Cooling Mode Performance

Rated Cooling	17,000 BTU/hr
Ambient Range	5~131°F
SEER2 Rating	20.3 BTU/W·h
EER2 Rating	11.0 BTU/W·h

* 100% Capacity @ Indoor DB 80°F / WB 67°F

Heating Mode Performance

Rated Heating	18,000 BTU/hr
Ambient Range	-13~86°F
HSPF2 IV (V)	10.0 (9.2) BTU/W·h
COP2 (47°F)	2.8 W/W

Heating (17°F) = 14,500 BTU / Heating (5°F) = 13,200 BTU / COP2 (5°F) = 1.8 W/W

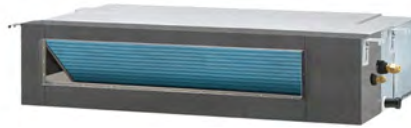

Ceiling-Concealed Ducted Indoor Unit



Outdoor Condensing Unit



User-Selected Installation Kit



Handheld Remote Controller

Electrical Information

	Cooling	Heating
Rated Input (W)	1,450	1,805
Rated Current (A)	6.3	7.8
Breaker Needed	20A (Double-Pole)	
Power Supply	208~230V, 60Hz, 1Ph	

Piping and Refrigerant

Liquid Line (OD)	1/4 in
Suction Line (OD)	1/2 in
Refrigerant Precharge	R-454b(Supports 10-25ft.)
Max Length/Height Diff.	65 ft. / 50 ft.

This combination is Energy-Star certified.



Interior Unit (Air Handler) Specifications

Type	Heat Pump
Sound Level (dBA)	41 (Hi) / 38 (Med) / 36 (Lo)
Auto Air Circulation	2-Way Louver (Up-Down + Left-Right)
Dimensions (WDH)	35-1/2 in x 19-1/4 in x 7-7/8 in
Weight (lbs)	39.7

Exterior Unit (Condenser) Specifications

Sound Level (dBA)	53
Recommended Room Size	500~750 Sq. ft.
Minimum Room Size	51 Sq. ft.
Compressor	Inverter-Driven Rotary
Dimensions (WDH)	36-1/2 in x 15 in x 27-1/2 in
Weight (lbs)	90.4

RT018GLSILCFHG Air Handler Dimensional Data

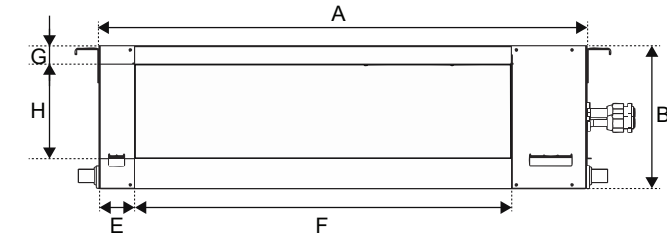

Supply Side

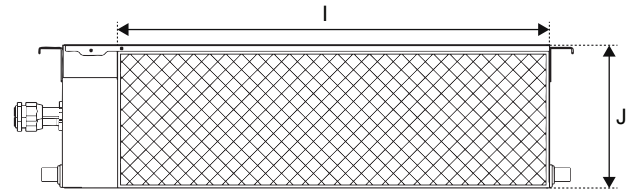

Inlet Side

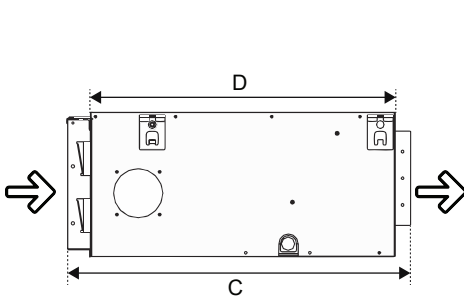

Side View

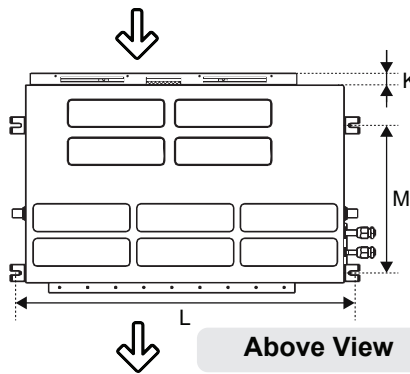

Above View

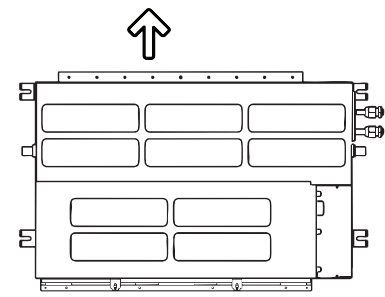

Below View

Overall Air Handler Dimensions				Front Side Air Outlet (Supply)				Rear Side Air Inlet (Return)			Mounting Brackets	
A	B	C	D	E	F	G	H	I	J	K	L	M
36-1/4 in	7-7/8 in	19-3/8 in	17-3/4 in	1-3/4 in	28-3/4 in	1/8 in	5-1/2 in	32-1/4 in	7-3/8 in	1-3/8 in	37-3/4 in	11-3/4 in
920.8 mm	200 mm	492.1 mm	450.9 mm	44.5 mm	730.3 mm	3.2 mm	139.7 mm	819.2 mm	187.3 mm	34.9 mm	958.9 mm	298.5 mm

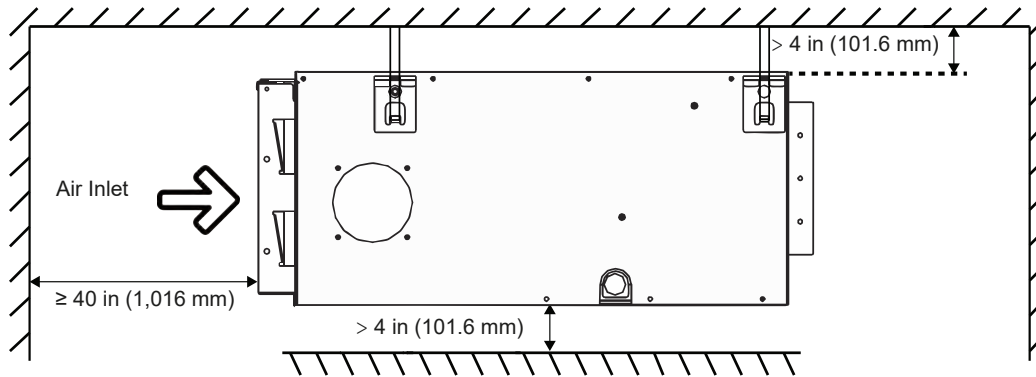

Side View

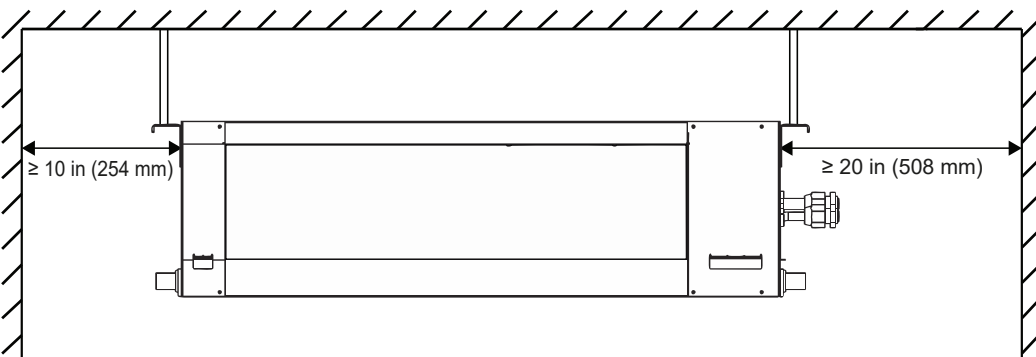

Front View

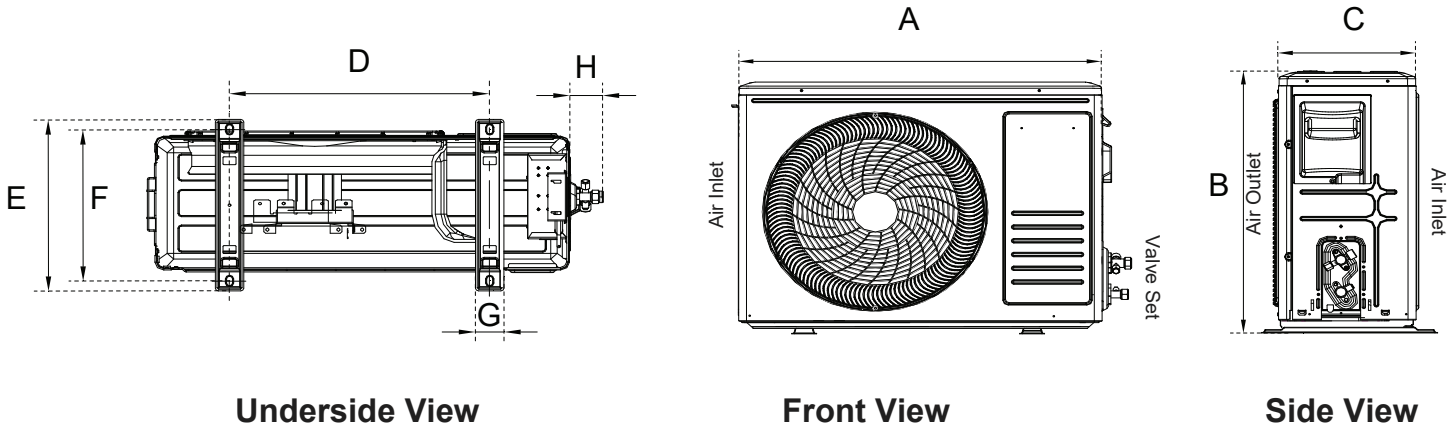

Model	A	B	C	D	E	F	G	H
YN018GLSI24RPG	33-1/4 in	27-1/2 in	12-7/8 in	23-1/8 in	14-3/4 in	13-3/4 in	2-1/8 in	2-1/4 in
	845 mm	699 mm	326 mm	586 mm	375 mm	348 mm	55 mm	55.9 mm

Warranty Information and Length



Complete warranty details are available with the vendor or online at <https://www.pdhvac.com/support/warranty/>. This high quality system is eligible for up to 10 years limited warranty on the compressor, and 7 years on other internal parts. To qualify for this warranty, the system must be installed within 90 days by a registered technician. All other installations that are registered default to 5 years parts/compressor. Products unregistered qualify for only 1 year parts/compressor warranty.

Outstanding Features

- LED Display
- Energy Saving
- Ultra-Thin Design
- Dual Drain Options
- Customizable Timer
- Eco-Friendly Refrigerant
- Whisper-Quiet Operation
- Power Loss Memory Recovery



Available Accessories

Part Number	Description
IKT-LCVR4P-KIT	<i>Decorative PVC Line Cover Kit</i>
IKT-LNBR-1/4-3/8	<i>BendAid Flexible Easy Bender Kit</i>
BRK-FRM-C-2P	<i>Folding Mounting Bracket w/ Leveler</i>
IKT-UVL32UL-AG	<i>UVC Bacterial Disinfection Kit</i>
IKT-SURPRK-DV2	<i>Ultimate Surge and Power Protection</i>