

Job Name:	
Submitted By:	



**Submittal Sheet For: RT012GLSILCFHG / YN012GLSI24RPG**

Date \_\_\_\_\_  
 Ref. \_\_\_\_\_

**Ceiling-Concealed Ducted 19SEER Inverter Heat Pump**

System Full Set Model: **RYT012GLSI24RL**  
 AHRI Reference Number: **217048763**

**Cooling Mode Performance**

Rated Cooling	11,000 BTU/hr
Ambient Range	5~131°F
SEER2 Rating	19.0 BTU/W·h
EER2 Rating	11.0 BTU/W·h

\* 100% Capacity @ Indoor DB 80°F / WB 67°F

**Heating Mode Performance**

Rated Heating	12,000 BTU/hr
Ambient Range	-13~86°F
HSPF2 IV (V)	8.4 (7.3) BTU/W·h
COP2 (47°F)	3.34 W/W

Heating (17°F) = 10,200 BTU / Heating (5°F) = 8,800 BTU / COP2 (5°F) = 1.8 W/W



Ceiling-Concealed Ducted Indoor Unit



Outdoor Condensing Unit



User-Selected Installation Kit



Handheld Remote Controller

**Electrical Information**

	Cooling	Heating
Rated Input (W)	940	1,030
Rated Current (A)	4.1	4.5
Breaker Needed	15A (Double-Pole)	
Power Supply	208~230V, 60Hz, 1Ph	

**Piping and Refrigerant**

Liquid Line (OD)	1/4 in
Suction Line (OD)	3/8 in
Refrigerant Precharge	R-454b(Supports 10-50ft.)
Max Length/Height Diff.	50 ft. / 33 ft.

This combination is Energy-Star certified.



**Interior Unit (Air Handler) Specifications**

Type	Heat Pump
Sound Level (dBA)	43 (Hi) / 41 (Med) / 39 (Lo)
Auto Air Circulation	2-Way Louver (Up-Down + Left-Right)
Dimensions (WDH)	27-1/2 in x 19-1/4 in x 7-7/8 in
Weight (lbs)	33.1

**Exterior Unit (Condenser) Specifications**

Sound Level (dBA)	52
Recommended Room Size	350~500 Sq. ft.
Minimum Room Size	40 Sq. ft.
Compressor	Inverter-Driven Rotary
Dimensions (WDH)	31-7/8 in x 12 in x 21-5/8 in
Weight (lbs)	58.4

# RT012GLSILCFHG Air Handler Dimensional Data **PIONEER**

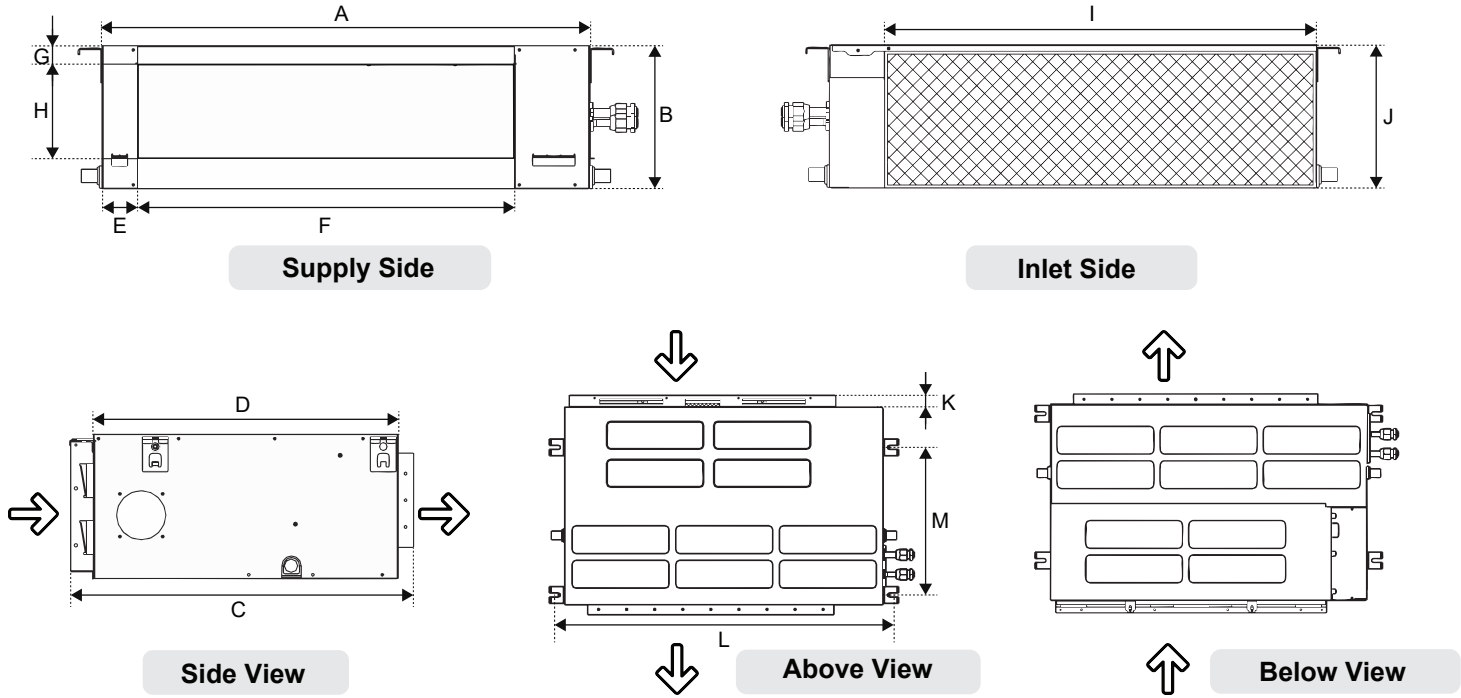

Overall Air Handler Dimensions				Front Side Air Outlet (Supply)				Rear Side Air Inlet (Return)			Mounting Brackets	
A	B	C	D	E	F	G	H	I	J	K	L	M
27-5/8 in	7-7/8 in	19-3/8 in	17-3/4 in	1-3/4 in	20-1/8 in	1/8 in	5-1/2 in	23-5/8 in	7-3/8 in	1-3/8 in	29-1/8 in	11-3/4 in
701.7 mm	200 mm	492.1 mm	450.9 mm	44.5 mm	511.2 mm	3.2 mm	139.7 mm	600.1 mm	187.3 mm	34.9 mm	739.8 mm	298.5 mm

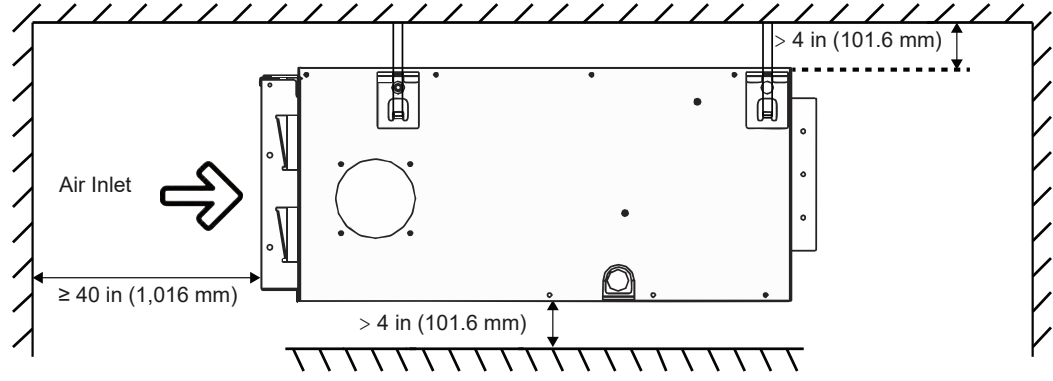

Side View

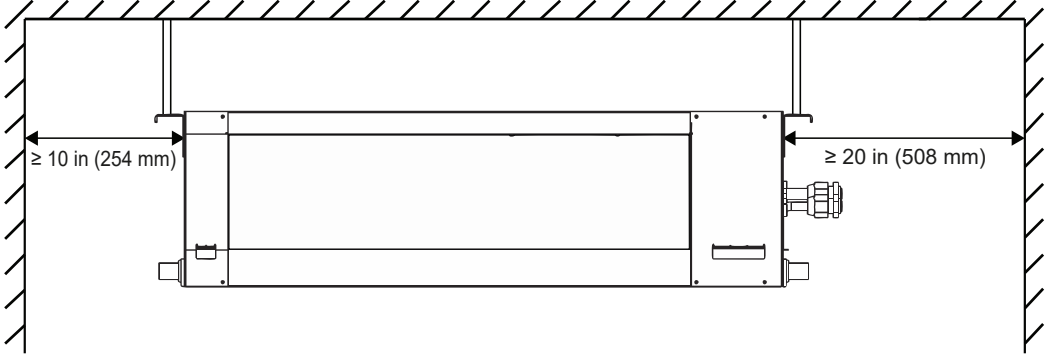

Front View

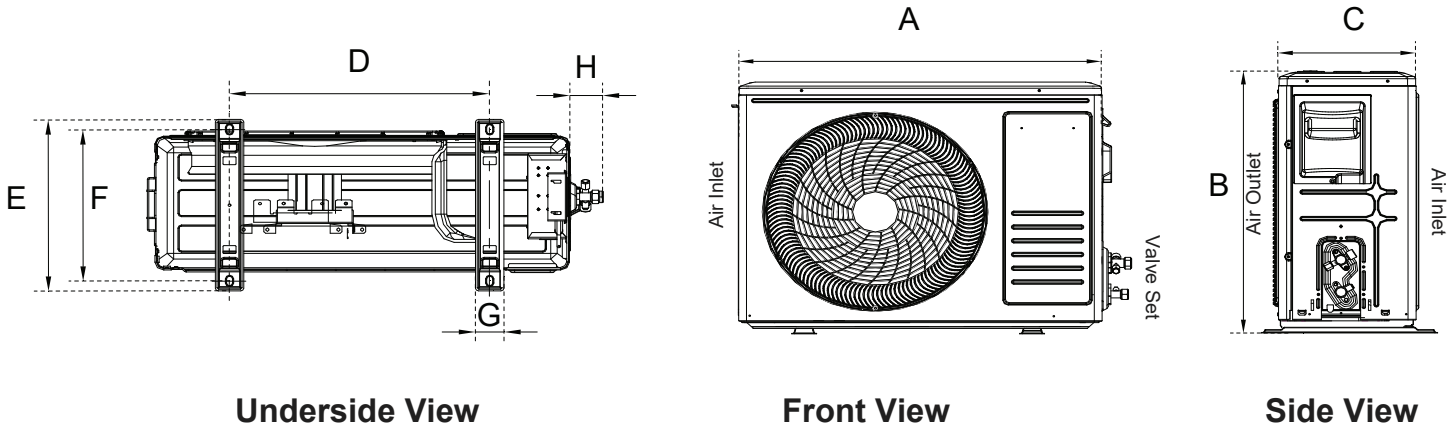

Model	A	B	C	D	E	F	G	H
YN012GLSI24RPG	29-1/8 in	21-3/4 in	10 in	17-1/8 in	12 in	11-1/4 in	1-7/8 in	2-1/4 in
	741 mm	551 mm	253 mm	434 mm	305 mm	285 mm	48 mm	58 mm

### Warranty Information and Length



Complete warranty details are available with the vendor or online at <https://www.pdhvac.com/support/warranty/>. This high quality system is eligible for up to 10 years limited warranty on the compressor, and 7 years on other internal parts. To qualify for this warranty, the system must be installed within 90 days by a registered technician. All other installations that are registered default to 5 years parts/compressor. Products unregistered qualify for only 1 year parts/compressor warranty.

### Outstanding Features

- LED Display
- Energy Saving
- Ultra-Thin Design
- Dual Drain Options
- Customizable Timer
- Eco-Friendly Refrigerant
- Whisper-Quiet Operation
- Power Loss Memory Recovery



### Available Accessories

Part Number	Description
IKT-LCVR4P-KIT	<i>Decorative PVC Line Cover Kit</i>
IKT-LNBR-1/4-3/8	<i>BendAid Flexible Easy Bender Kit</i>
BRK-FRM-C-2P	<i>Folding Mounting Bracket w/ Leveler</i>
IKT-UVL32UL-AG	<i>UVC Bacterial Disinfection Kit</i>
IKT-SURPRK-DV2	<i>Ultimate Surge and Power Protection</i>