

# G-ZN30 MultiSINK



## G-ZN30 18ga Double Bowl MultiSINK Kit with WaterWALL

Includes a 33" X 22" X D10" 18ga 304 Stainless Steel, Dual Mount, 50/50 Multi Level Kitchen Sink with WaterWALL. A 304 Stainless Steel, Patented High Neck Faucet and Tailor-Made Accessories

### MultiSINK Features:

- High grade, durable 304 Stainless Steel Dual-Bowl 50/50 with Modern Thin Central Dam
- Revolutionary adjustable-angle **WaterWALL** rinsing ensures thorough cleaning of vegetables and fruits, large plates and chopping board with ease
- Dual mount sink, can be top mount or under mount. All hardware included
- Expertly handcrafted sink with a precision slope for effortless drainage, combining functionality with timeless elegance
- Designed with a 5mm radius on each corner for a sleek look and easy maintenance
- Two high grade, durable 304 Stainless Steel 16.85" x 14.8" Roll-up Grids. Its heavy-duty grade can carry pots & pans and its roll-up capabilities make them very easy to store away. They also provide you with a completely flat working area at the bottom of your sink!
- Two Modern Stainless Steel Strainer with high capacity basket to collect debris



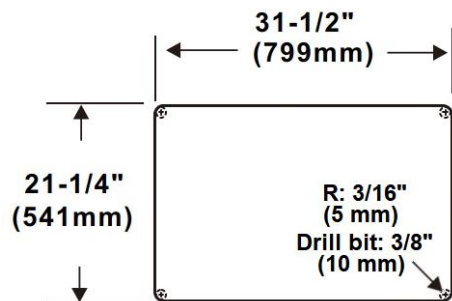
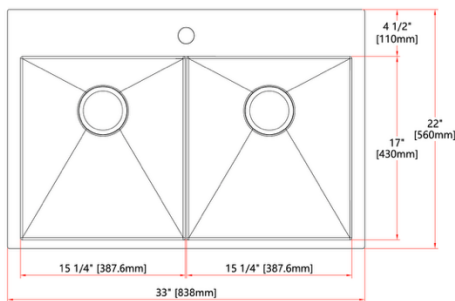
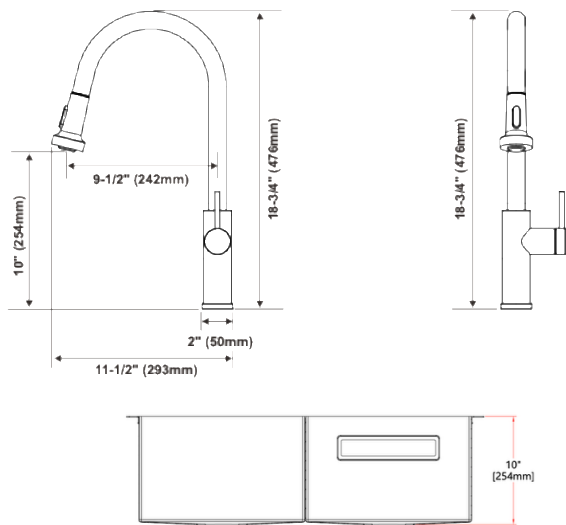

Cutout for Top mount & Under mount 3/8" reveal

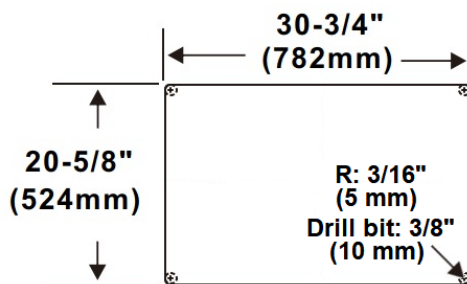

Cutout for Under mount Zero reveal

NSF/ANSI/CAN 372  
NSF/ANSI/CAN 61



FORNO ACQUA offers you ONLY certified products — including every component — for safety and compliance — ensuring reliability, safety and lasting performance.

### Faucet Features:

- **Patented Retractable Faucet design – No counter weight is needed. No extra hose under cabinet. Giving more room inside cabinet for storage. Pull out can stay. Hands free convenience.** When water is turned off, pull out spout will automatically retract back into place.
- **High Grade Stainless Steel Faucet with Three Distinct handy functions:** Strong Blade Boost for power washing; Aeriated for regular water flow; and Spray for rinsing.
- Modern Look, High Neck Faucet maximizes sink space

### Sink & Accessories Specifications:

- SS304 Dual Mount MultiSINK L33" x D22" x D10" 18ga 50/50 Double Bowl (IAPMO Approved)
- Two SS304 Large Roll-Up Grids L16.85" x W14.8"
- Two Stainless Steel Strainers (cUPC Approved)

### Kitchen Faucet Specifications:

- H18-3/4" Stainless Steel 304 Retractable Kitchen Faucet
- Three Function Faucet Head
- Plumbing IAPMO Approved, Max.1.8GPM
- NSF/ANSI/CAN 372 Lead Free Plumbing Approved
- NSF/ANSI/CAN 61 Drinking Water Health Systems-Health Effect Approved

### WaterWALL Specifications:

- Large Swivel angle with convenient pivoting action
- Overall Length 9-1/4"
- Faucet-controlled
- Plumbing IAPMO Approved, Max.1.8GPM
- NSF/ANSI/CAN 372 Lead Free Plumbing Approved
- NSF/ANSI/CAN 61 Drinking Water Health Systems-Health Effect Approved

### Packaging:

- ISTA 6 Certified E-Commerce Packaging – Drop test for reliable delivery
- N.W: 38.5 LBS (17.5 KGS); G.W: 50.7 LBS (23 KGS)

CTM Maison Elite Inc.  
11420 Albert Hudon, Montreal,  
Quebec, Canada H1G 3J6  
1-866-231-8893  
Info@ctmmaisonelite.com  
www.CTMMaisonElite.com

